

COOLZONE[®]

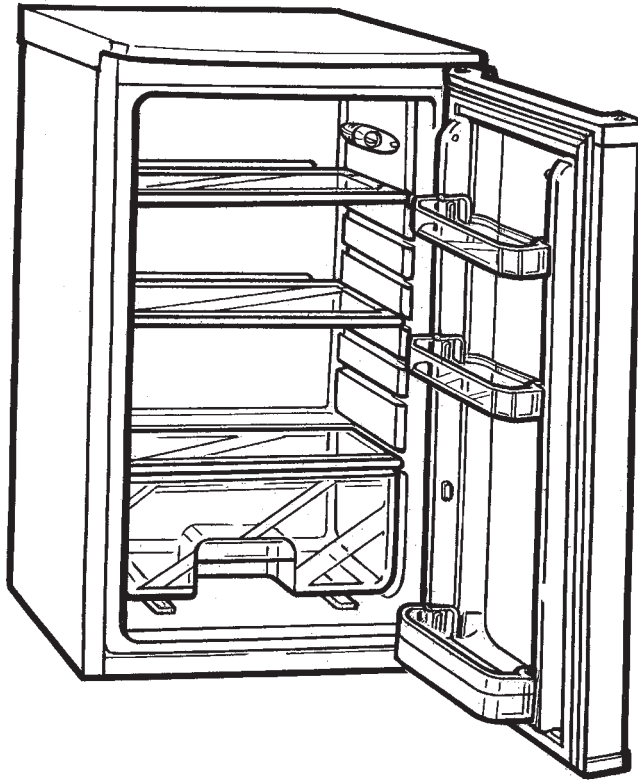

CZ51057L
Larder fridge

USER INSTRUCTIONS

Please read these instructions carefully before using this product and keep them safe for future reference.

Page contents

Before use	2
Do and Don't	2
Parts identification	3
Installation	3
Door reversal	3,4
Controls	5
Maintenance and cleaning	6
Troubleshooting	7
Fuse and mains plug replacement	7
Specification	8
After sales service	8
Safety measures and disposal	8

Before Use

Packaging

The packaging is recyclable so dispose of it according to local regulations. Keep the packaging materials out of reach of young children. Before installation take care to remove all cardboard or other packaging, including material from the condenser tubes and any material surrounding the motor/compressor unit.

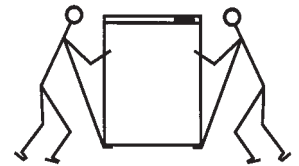

Warning

The fridge is heavy and care is needed when unpacking and moving it. Get extra help and only hold it by the casing – not the door or trim.

Check the contents

Check the following contents are included with the product and inspect the casing for any damage. If necessary contact your retailer from whom you purchased the product.

1 x glass shelf over salad crisper
2 x glass shelves
Bottle rack

2 x balcony shelves
1 x plastic salad crisper

After unpacking, wipe the casing with a dry cloth and clean the inside with a damp cloth ready for food storage.

Do and Don't

- ❖ Do read these instructions thoroughly before using this appliance.
- ❖ Do install the appliance only in the vertical position.
- ❖ Do let your refrigerator stand for 12 hours prior to connection, to allow the cooling gases to stabilise, if transported in a horizontal position.
- ❖ Do install to allow for adequate ventilation around the appliance.
- ❖ Do not install near heaters or other heat sources.
- ❖ Do unplug before cleaning and maintenance.
- ❖ Don't install the appliance in humid or extreme conditions.
- ❖ Don't attempt to repair the appliance yourself (see Helpline information – page 8).
- ❖ This appliance is intended for domestic use only. Only use it in accordance with the manufacturer's instructions.
- ❖ Don't use any other electrical device inside the appliance to defrost.
- ❖ Don't store goods containing inflammable or other explosive gases.
- ❖ Don't leave door closed if appliance is left switched off for long periods.

Parts identification

The parts are listed and numbered below to help identification.

1. Thermostat and lamp housing
2. Glass shelves
3. Salad/vegetable crisper
4. Balcony shelves
5. Bottle rack

FIGURE 1

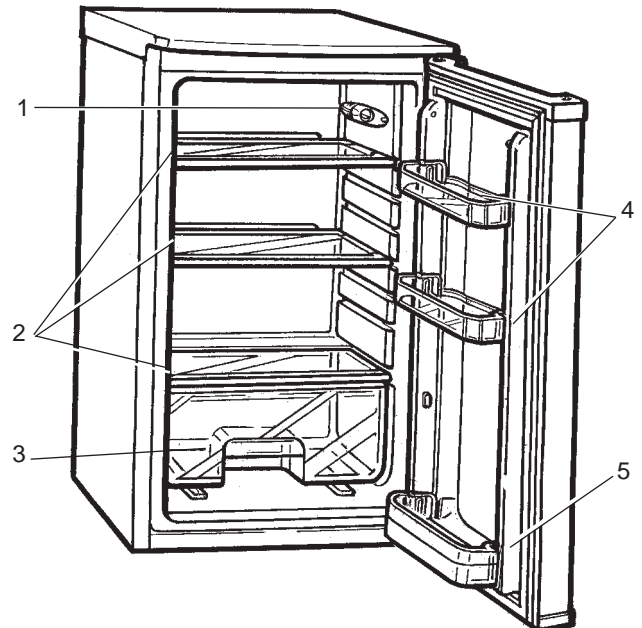

Installation

Important

Make sure that the voltage marked on the rating label on the product corresponds with the voltage in your home.

This quality product has been tested and certified to meet all applicable UK electrical and safety standards.

The appliance is designed to work in room temperatures between +16°C and +32°C. Do not allow the room temperature to exceed +32°C otherwise the temperature inside the fridge will rise.

The fridge requires space around the casing for efficient cooling and operation. The minimum clearances are shown in Figure 2.

There must be at least 100mm clearance between the appliance and the rear wall

The refrigerator must be installed on a firm flat and level surface for it to work quietly and efficiently.

FIGURE 2

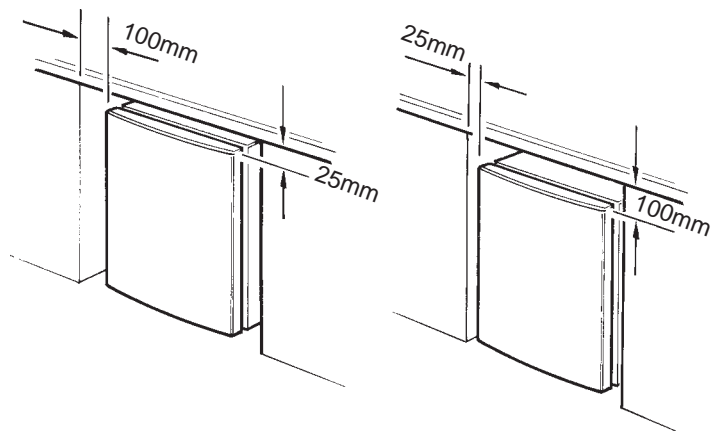

Diagrams show alternative methods of providing correct air flow around the appliance.

Door reversal

Reversing the door may make installation more convenient. The appliance must be tilted and supported in order to carry this out; it is therefore advisable to get an assistant to help during this procedure. Take care when fitting and tightening screws.

Unscrew and remove the adjustable foot (Figure 3).

FIGURE 3

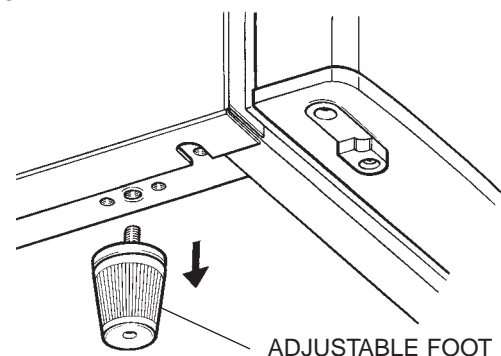

Door reversal (cont)

FIGURE 4

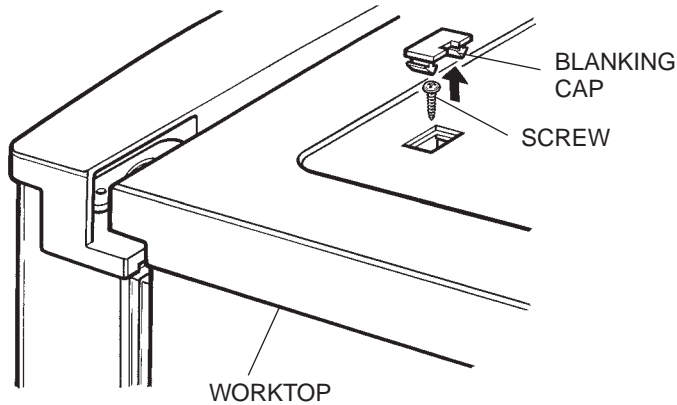

Release the blanking caps and unscrew and remove the screws securing the top of the worktop (Figure 4).

FIGURE 5

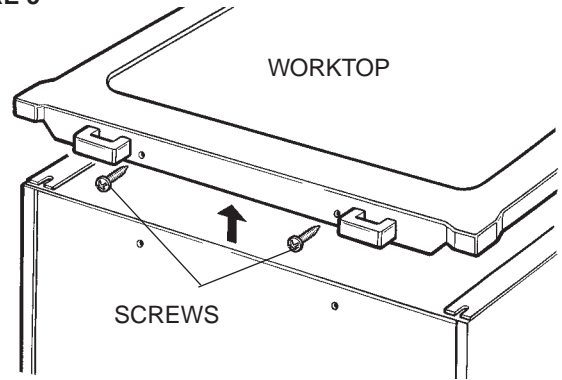

Remove the two screws securing the rear of the worktop (Figure 5).
Lift away the worktop from the appliance and place it safely to one side.

FIGURE 6

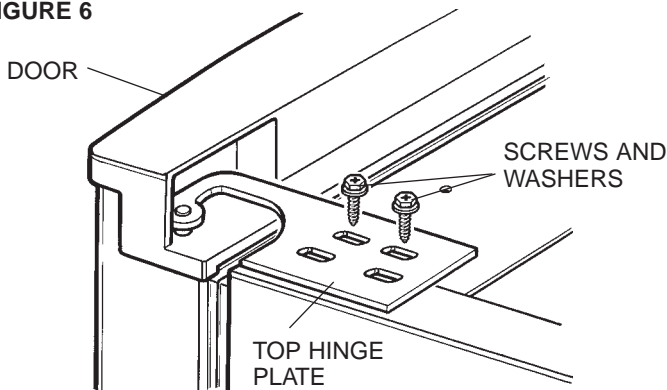

Support the door and remove the top hinge plate (Figure 6).

FIGURE 7

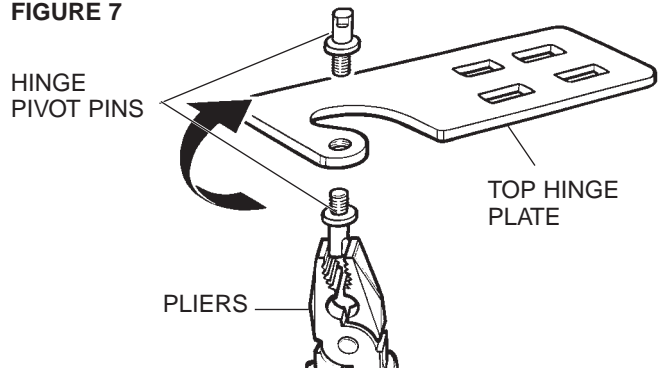

Grip the hinge pivot pins to unscrew them from the top hinge plate. Refit the pin to the opposite side of the hinge plate (Figure 7).

FIGURE 8

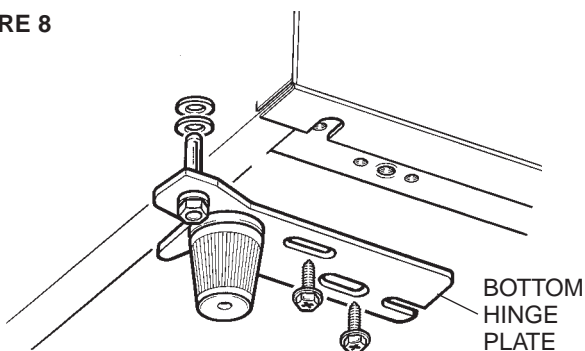

Remove the bottom hinge plate (Figure 8).

FIGURE 9

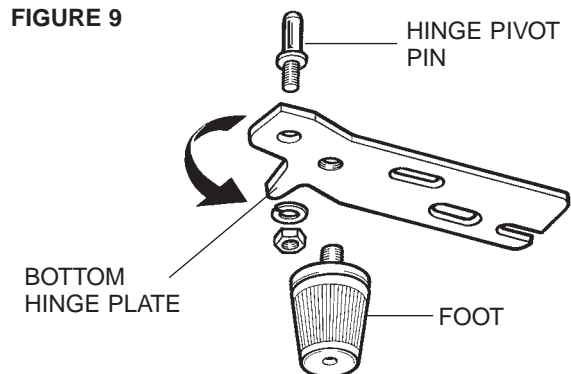

Refit the hinge pivot pin on to the opposite side of the bottom hinge plate (Figure 9). Replace the foot.
Remove any blanking plugs from the door and replace them on the opposite side.
Locate the top hinge pivot pin in the top of the door and replace the bottom hinge plate to secure the door.
Replace feet and level the appliance.

Controls

Switching on

Plug the appliance into a nearby power socket and switch on. The temperature control (Figure 10) is positioned inside the fridge by the light. Turn the control to a half-way position on the dial and leave the appliance running with the door closed for approximately 2 hours. This will allow the inside temperature to stabilise.

Temperature control

The temperature of the fridge is best maintained around 0°C to + 5°C. Avoid setting the thermostat too high otherwise this may reduce the temperature to a point at which certain fresh foods may begin to freeze. The temperature setting runs from 1, the warmest setting, to 7, the coldest. The 0 position is an OFF setting which can be used when the refrigerator is standing empty. Figure 10. Turn the temperature control so the number is visible.

When storing food in the fridge keep food away from the rear wall. To allow free circulation of cold air don't pack food too tightly on the shelves and never put hot food in the fridge.

FIGURE 10

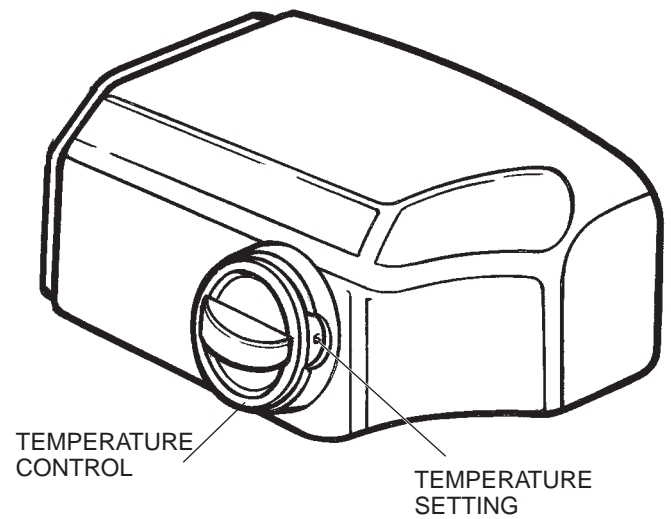

Notes on operation

During normal operation the following noises may be heard:

- ❖ Stifled murmur from compressor when it is working.
- ❖ Soft gurgling from the refrigerant flowing through the cooling system.
- ❖ Click from the thermostat switching on and off.

Maintenance and cleaning

Important

The fridge must be turned off at the mains before maintenance or cleaning.

General cleaning

It is recommended to clean and wipe out the fridge regularly or after any spillage inside or outside the appliance.

Use a teaspoonful of bicarbonate of soda diluted in a pint of warm water. Wipe the internal surfaces and shelving to remove food residues. Leave to dry before reloading food.

Beware of the back wall as this may be cold to the touch. Avoid wiping this until it has thoroughly defrosted.

Wipe the outside casing from time to time in order to remove dirt and dust from ventilation vents etc.

Keep water away from the thermostat housing.

Clean the door seals.

Remove accumulated dirt from around the compressor motor taking care not to damage the pipes and the wiring.

Defrosting

It is recommended to regularly defrost the fridge to ensure efficient operation.

The frost on the internal surfaces must not exceed 6mm before defrosting.

Turn the temperature control to '0'.

Remove food from the fridge keep the door open and wait until the frost has melted. Do not use metal utensils to remove frost.

When defrosted turn the temperature control to the desired setting and replace the food.

Drainage channel

Water collects in the drainage channel on the back wall. It then passes to a drip tray over the compressor from which it evaporates. The drain should be cleaned regularly to avoid the build up of impurities. Wipe the channel with a damp cloth and use a small bottle brush, pipe cleaner or similar flexible object to clean out any residue from the drainage hole.

FIGURE 11

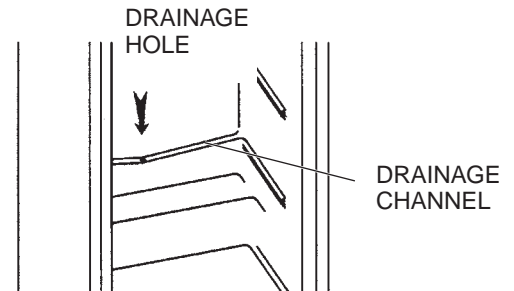

Lamp replacement

To remove the lamp cover, grip the light diffuser (Figure 12) and gently sliding the diffuser outwards away from the thermostat housing. Unscrew the lamp and replace it with one of the same type, (15 watts SES E14). Replace the cover by reversing the procedure.

FIGURE 12

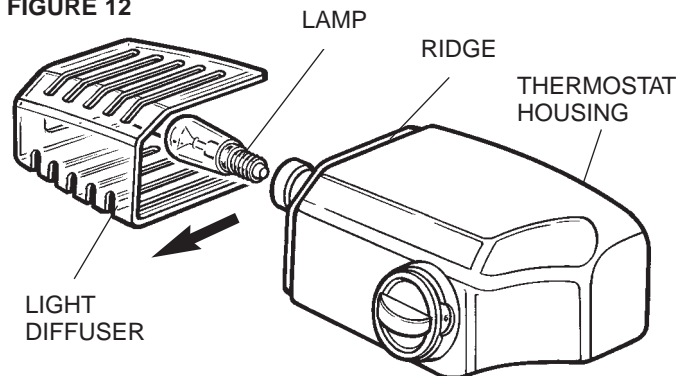

Troubleshooting

Problem	Possible cause	Remedy
The lamp does not light	The lamp has blown	Replace the lamp with same type: 15W, SES, E14
There is water at the bottom of the fridge	Drainage hole and/or pipe blocked	Clean/unblock hole and pipe
The motor is on for long periods without switching off	Door opened too often The airflow around the unit is inadequate	Do not open door needlessly Allow more free space around the unit
Motor not working	No power to unit	Check fuses, plug, and power supply
Fridge is not cold enough	Thermostat set too low	Turn to higher setting

Fuse and mains plug replacement

This product is supplied with a moulded plug which contains a 13A fuse. If you are simply replacing the fuse, you must use a 13A fuse which has been approved by ASTA to BS1362 (Figure 13).

If the plug does not fit the socket or becomes damaged, a new plug must be fitted. Replace the original plug with the correct plug for your socket. If this is a 3-pin (square pin) 13A (BS1363) plug, you must make sure that it is fitted with an ASTA approved 13A fuse.

Never use without the fuse cover fitted.

If another type of plug is used, it must be protected by a 15A fuse, either in the plug or at the distribution board.

1. Cut off the existing fitted plug.
2. The wires in the mains lead supplied with this appliance are coloured in accordance with the following code (Figure 14):

GREEN/YELLOW = EARTH (E)
 BLUE = NEUTRAL (N) BROWN = LIVE (L)

This product must be earthed

As the colours of the wires in the mains lead may not correspond with the colour markings identifying the terminals in your new plug, proceed as follows.

The wire which is coloured GREEN or YELLOW/GREEN must be connected to the terminal which is marked with the letter E or \oplus symbol or coloured GREEN or YELLOW/GREEN.

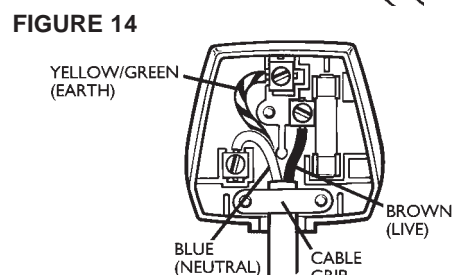
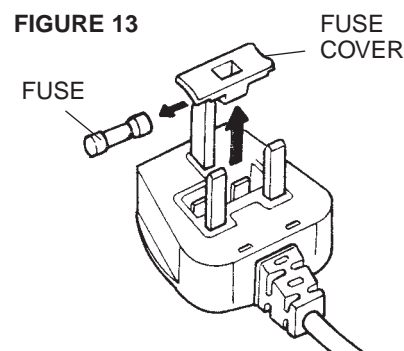

The wire which is coloured BLUE must be connected to the terminal in the plug which is marked with the letter N or coloured BLACK or BLUE.

The wire which is coloured BROWN must be connected to the terminal which is marked with the letter L or coloured RED or BROWN.

3. Ensure that the connections are tight and that no loose strands are left out of the terminals.

IF IN ANY DOUBT CONSULT A QUALIFIED ELECTRICIAN.

If the mains lead becomes damaged consult a qualified electrician.

Specification

Total net volume (litres)	98
Dimensions: HxWxD mm	850x480x495
Power supply	220/240V, 50Hz
Energy efficiency class	A
Refrigerant	R600a

Product specification may vary without prior notice.

After sales service

This appliance is guaranteed for a period of two years from date of purchase against defects in materials and workmanship only, and provided that all these user instructions have been strictly complied with. The guarantee does not cover incidental or consequential loss, such as loss of consumables.

Where this guarantee applies, the appliance will be repaired or replaced at the manufacturer's option without charge. If the guarantee does not apply or has expired, you will be given a quotation for cost of repairs and any parts required.

Keep your purchase receipt with these instructions, and in the event of breakdown contact the HELPLINE on 0844 871 0011.

Safety measures and disposal

Never try to repair the appliance or the electrical parts yourself. Any repair carried out by an unskilled person is dangerous and may affect the guarantee. Contact the Helpline for assistance and advice.

Disposal of old fridge

Disposal of the appliance must conform with EU environmental regulations.

Make the appliance not usable by cutting off the mains lead and removing any door locks.

The appliance must be delivered to an authorised collection centre.



This appliance/fitting is marked according to the European directive 2002/96/EC on Waste Electrical and Electronic Equipment (WEEE). By ensuring this product is disposed of correctly, you will help prevent potential negative consequences for the environment and human health, which could otherwise be caused by inappropriate waste handling of this product.

The symbol on the product, or on the documents accompanying the product, the Crossed Out Wheellie Bin symbol, indicates that this appliance/fitting may not be treated as household waste. Instead it shall be handed over to the applicable collection point for the recycling of electrical and electronic equipment. Disposal must be carried out in accordance with local environmental regulations for waste disposal. For more detailed information about treatment, recovery and recycling of this product, please contact your local authority, your household waste disposal service or the retailer where you purchased the product.