

COOLZONE[®]



CZ51062
Table top fridge

USER INSTRUCTIONS

Please read these instructions carefully before using this product and keep them safe for future reference.

Before Use

Packaging

The packaging is recyclable so dispose of it according to local regulations. Keep the packaging materials out of reach of young children.

Warning

The fridge is heavy and care is needed when unpacking and moving it. Get extra help and only hold it by the casing – not the door or trim.

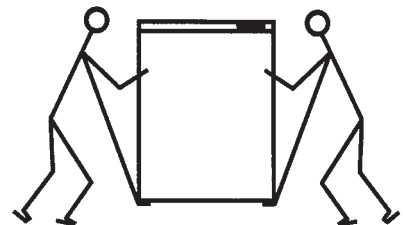

Check the contents

Check the following contents are included with the product and inspect the casing for any damage. If there is any damage, contact the retailer from whom you purchased the product.

- Removable tray
- Shelf x 1
- Drip tray
- Ice cube tray
- 2 keys

Parts identification

1. Ice box
2. Thermostat control
3. Removable tray
4. Door
5. Shelf x 1
6. Drip tray and ice cube tray

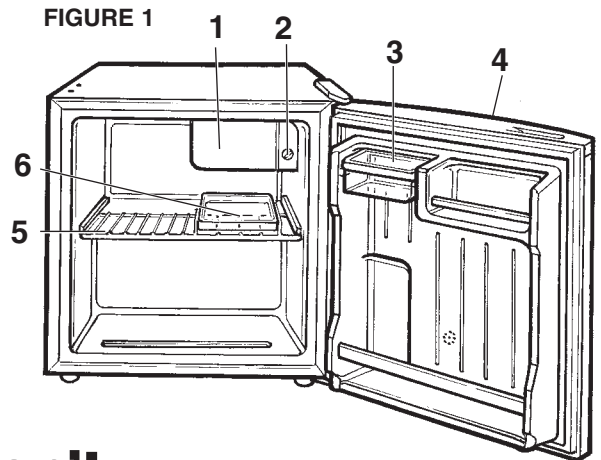

After unpacking, wipe the casing with a dry cloth and clean the inside with a damp cloth ready for use.

Do and Don't

- ❖ Do read these instructions thoroughly before using this appliance.
- ❖ Do install the appliance only in the vertical position.
- ❖ Do stand for 12 hours to allow the cooling gases to stabilise if transported in a horizontal position.
- ❖ Do install to allow for adequate ventilation around the appliance (see Figure 5).
- ❖ Do not install near heaters or other heat sources.
- ❖ Do unplug before cleaning and maintenance.
- ❖ Do defrost regularly for maximum efficiency.
- ❖ Don't install the appliance in humid or extreme conditions.
- ❖ Don't attempt to repair the appliance yourself (see Helpline information – back page).
- ❖ Only use it in accordance with the manufacturer's instructions.
- ❖ Don't use any other electrical device inside the appliance to defrost.
- ❖ Don't store goods containing inflammable or other explosive gases.
- ❖ Don't leave door closed if appliance is left switched off for long periods.
- ❖ Don't freeze food in the ice box. The ice box is not suitable for home freezing.

Door reversal

This appliance has the facility to hang the door on the opposite side.

Depending upon where you plan to locate the appliance, reversing the door may make access more convenient.

1. Remove the hinge cover, hinge screws, washers and hinge (Figure 2).
2. Lift the door off the lower hinge pin.
3. Unscrew the lower hinge bracket screws and remove the lower hinge bracket (Figure 3).
4. Remove the left-hand fixed foot (Figure 4).
5. Remove the adjustable foot from the lower hinge and turn the hinge upside down. Re-fit the pin and adjustable foot. Fit the lower hinge to left-hand side of the cabinet.
6. Remove the blanking caps which cover the left-hand fixing holes and fit them to the holes on the other side of the cabinet.
7. Support the door on the lower hinge pin. Take the hinge and locate the pin in the bush at the top of the door. Fit the hinge to the top of the cabinet with the hinge screws and washers. Fit the hinge cover.
8. Screw the fixed foot into the corresponding hole on the other side of the cabinet.

FIGURE 2

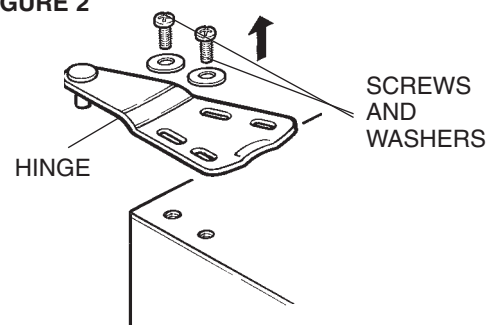

FIGURE 3

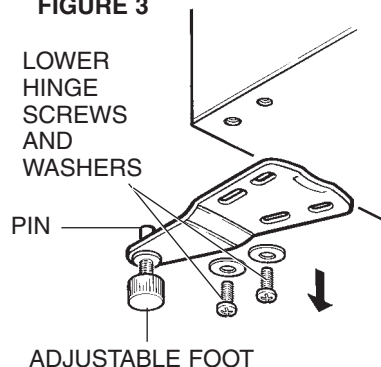
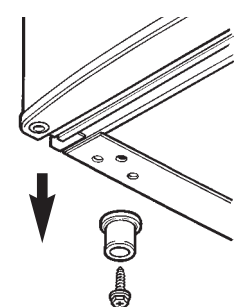

FIGURE 4



Installation and controls

Important

Make sure that the voltage marked on the rating label on the product corresponds with the voltage in your home. This quality product has been tested and certified to meet all applicable UK electrical and safety standards.

The appliance is designed to operate at normal room temperatures. Position it away from any heat source such as a boiler, ovens and heaters which will reduce the cooling efficiency of the fridge. It is also not advisable to install the appliance in unheated locations such as garages or outbuildings, as these will impair the operation of the fridge in winter.

The fridge requires space around the casing for efficient cooling and operation. The minimum clearances are shown in Figure 5.

The fridge must be installed on a firm, flat and level surface for it to work quietly and efficiently. If necessary, turn the thumbwheel foot to level the appliance.

Switching on

Plug the fridge into a nearby power socket and switch on. A humming from the compressor will indicate that the fridge is running.

Temperature control

Turn the thermostat control to a half-way position on the dial and leave the fridge running with the door closed for approximately 2 hours. This will allow the inside temperature to stabilise.

If you wish to decrease the temperature inside the fridge, turn the thermostat control to a higher number.

Note: The setting on the thermostat control is dependent upon room temperature and the external temperature.

FIGURE 5

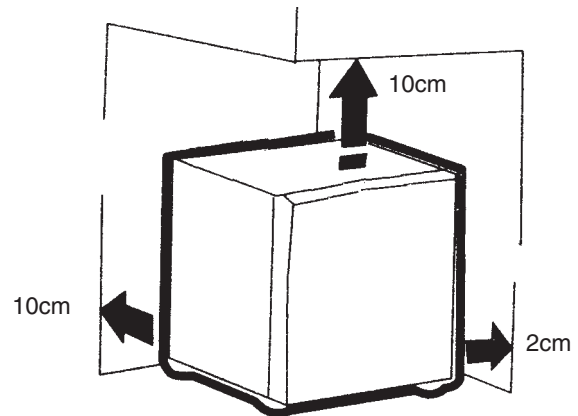

The diagram shows the correct air flow allowance that should be left around the appliance.

Notes on operation

During normal operation the following noises may be heard:

- ❖ Stifled murmur from compressor when it is working.
- ❖ Soft gurgling from the coolant flowing through the cooling system.
- ❖ Click from the thermostat switching on and off.

Maintenance and cleaning

Important: The fridge must be turned off at the mains before maintaining or cleaning. It is recommended to clean and wipe out the fridge after any spillage inside or outside the appliance. It is wise to defrost the condenser if the ice build up exceeds 6mm, otherwise the efficiency of the fridge will reduce and the electricity consumption will increase.

Caution: Do not touch ice with bare skin to avoid 'ice burns'.

Unplug and remove the fridge contents.

Leave the door open until ice has melted. Alternatively, a bowl of hot (not boiling) water placed under the condenser will hasten defrosting. A plastic scraper may be used as an aid to defrosting.

- ❖ Do not use electrical appliances such as heaters or hair dryers to melt the ice.

- ❖ Do not use metal objects such as knives or skewers to chip away the ice as these can damage the condenser.

Finally, wipe the interior surfaces and door seal using a teaspoonful of bicarbonate of soda diluted in a pint of warm water to remove any residues or odours.

Keep water away from the thermostat housing.

Keep the compressor motor (located at rear of casing) free from dust to maintain optimum efficiency. Use a soft brush or vacuum cleaner to remove the dust, taking care not to damage the pipes and wiring.

The external casing can be cleaned with warm soapy water and protected by polish. Do not use scouring powders which can scratch the surface.

Note: If leaving the fridge unused for a prolonged period, unplug from mains, defrost, wipe dry and leave the door open.

Troubleshooting

Problem	Possible cause	Remedy
Appliance does not run	No power Faulty fuse Thermostat setting too low	Check power is switched ON Check fuse in plug Turn thermostat setting higher
Fridge is not cold enough	Door is open for too long Located too near a heat source Inadequate airflow around appliance	Do not open door needlessly Relocate appliance See Figure 5
Abnormal noise and vibration	Appliance not level Cooling tubes touching cabinet or other parts	Choose a level surface Carefully ease away tubes from other parts

Fuse and mains plug replacement

This product is supplied with a fitted plug which contains a 13A fuse. If you are simply replacing the fuse, you must use a 13A fuse which has been approved by ASTA to BS1362.

If the plug does not fit the socket or becomes damaged, a new plug must be fitted. Replace the original plug with the correct plug for your socket. If this is a 3-pin (square pin) 13A (BS1363) plug, you must make sure that it is fitted with an ASTA approved 13A fuse.

If another type of plug is used, it must be protected by a 15A fuse, either in the plug or at the distribution board.

1. Cut off the existing fitted plug.

2. The wires in the mains lead supplied with this appliance are coloured in accordance with the following code (Figure 6):

GREEN/YELLOW = EARTH (E) BLUE = NEUTRAL (N) BROWN = LIVE (L)

This product must be earthed.

As the colours of the wires in the mains lead may not correspond with the colour markings identifying the terminals in your new plug, proceed as follows.

The wire which is coloured GREEN or YELLOW/GREEN must be connected to the terminal which is marked with the letter E or ⊕ symbol or coloured GREEN or YELLOW/GREEN.

The wire which is coloured BLUE must be connected to the terminal in the plug which is marked with the letter N or coloured BLACK or BLUE.

The wire which is coloured BROWN must be connected to the terminal which is marked with the letter L or coloured RED or BROWN.

3. Ensure that the connections are tight and that no loose strands are left out of the terminals.

IF IN ANY DOUBT CONSULT A QUALIFIED ELECTRICIAN.

If the mains lead becomes damaged consult a qualified electrician.

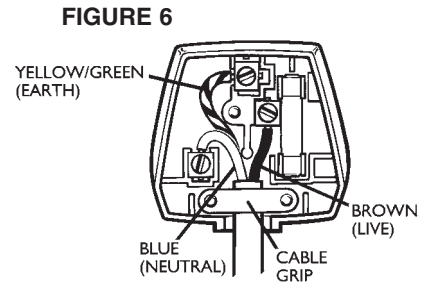

Specification

Capacity (litres)	50
Dimensions: HxWxD mm	480x470x450
Power consumption (Watts)	68
Power supply	220/240V, 50Hz
Nominal daily consumption (kWh/24h)	0.55
Energy efficiency class	B
Refrigerant	R134a

Product specification may vary without prior notice.

After sales service

This appliance is guaranteed for a period of two years from date of purchase against defects in materials and workmanship only, and provided that all these user instructions have been strictly complied with. The guarantee does not cover incidental or consequential loss, such as loss of consumables.

Where this guarantee applies, the appliance will be repaired or replaced at the manufacturer's option without charge. If the guarantee does not apply or has expired, you will be given a quotation for cost of repairs and any parts required.

Keep your purchase receipt with these instructions, and in the event of breakdown contact the HELPLINE on 0844 871 0011.

**For Faults and Assistance Helpline
Phone: 0844 871 0011**

Safety measures

Never try to repair the appliance or the electrical parts yourself. Any repair carried out by an unskilled person is dangerous and may affect the guarantee. Contact the Helpline below for assistance and advice.

Disposal of old chiller

Disposal of the appliance must conform with EU environmental regulations.

Cut off the mains lead and remove any door locks to ensure the appliance is beyond further use.

The appliance must be delivered to an authorised collection centre.

This appliance/fitting is marked according to the European directive 2002/96/EC on Waste Electrical and Electronic Equipment (WEEE). By ensuring this product is disposed of correctly, you will help prevent potential negative consequences for the environment and human health, which could otherwise be caused by inappropriate waste handling of this product.

The symbol on the product, or on the documents accompanying the product, the Crossed Out Wheelie Bin symbol, indicates that this appliance/fitting may not be treated as household waste. Instead it shall be handed over to the applicable collection point for the recycling of electrical and electronic equipment. Disposal must be carried out in accordance with local environmental regulations for waste disposal. For more detailed information about treatment, recovery and recycling of this product, please contact your local authority, your household waste disposal service or the retailer where you purchased the product."

