

COOLZONE[®]



CZ51063
Full size dishwasher

USER INSTRUCTIONS

Please read these instructions carefully before using this product and keep them safe for future reference.

Page contents

Before use3
Do and don't3
Parts identification3
Installation4
Salt5
Detergent and rinse aid6
Loading the dishwasher7
Control panel8
Starting the dishwasher8
Wash cycle table9
Energy saving tips9
How to keep your dishwasher in shape10
Cleaning and maintenance10
Troubleshooting12
Fuse and mains plug replacement13
Specification14
Safety measures14
After sales service14

Before use

Packaging

The packaging is recyclable so dispose of it according to local regulations. Keep the packaging materials out of reach of young children.

Warning

The dishwasher is heavy and care is needed when unpacking and moving it. Get extra help and only hold it by the casing – not the door or trim.

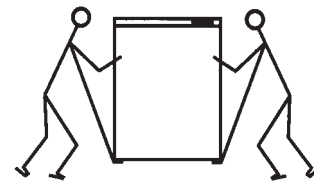

Check the contents

Check the following contents are included with the product and inspect the casing for any damage. If necessary, contact your retailer from whom you purchased the product.

- Mains lead and mains plug
- Water drain hose
- 2 x wire baskets
- Water inlet connection hose
- Cutlery basket
- Funnel

Important

Make sure that the voltage marked on the rating label on the product corresponds with the voltage in your home.

This quality product has been tested and certified to meet all applicable UK electrical and safety standards.

Do and don't

- ❖ Do install the appliance only in the vertical position.
- ❖ Do unplug before cleaning and maintenance.
- ❖ Do turn off the water supply and disconnect the electricity supply if the appliance malfunctions.
- ❖ Do only use this appliance in accordance with the manufacturer's instructions.
- ❖ Do make the appliance safe when disposing of it by cutting the mains lead and removing the door lock.
- ❖ Do keep detergents away from children
- ❖ Do keep children away from the appliance when it is open.
- ❖ Don't place anything heavy (or water containers) on the top of the dishwasher.
- ❖ Don't attempt to repair the appliance yourself (see Helpline information – page 13).
- ❖ Don't use this appliance when barefoot or with wet hands.
- ❖ Don't use extension leads or multiple sockets.
- ❖ Don't open the door when the machine is working.

Parts identification

To release the door, pull the catch towards you which is located in the door handle recess.

The parts are numbered below to help identification. Ensure all the parts are present and that none are broken.

FIGURE 1

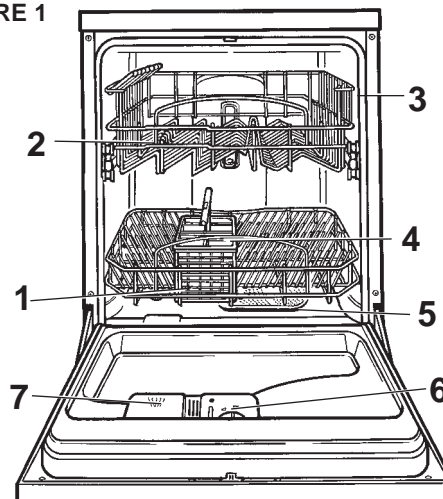

1. Bottom basket
2. Top basket
3. Door seal
4. Cutlery basket
5. Filter
6. Rinse aid
7. Detergent dispenser

Installation

Positioning the appliance

When deciding on a location for the appliance, please bear the following points in mind:

- The depth of the unit from front to back is roughly the same as the majority of work surfaces. This means there is not enough room for any pipes etc. to be positioned at the rear of the unit. To facilitate this, the dishwasher is designed with the water supply and drain hoses positioned to the right and left for correct installation. The back rests against the wall.
- The lower plinth for the kitchen base units will need to be removed for installation.
- The minimum dimensions of the space required for the appliance are shown in Figure 2.
- Level the appliance by the adjustable foot (Figure 3).

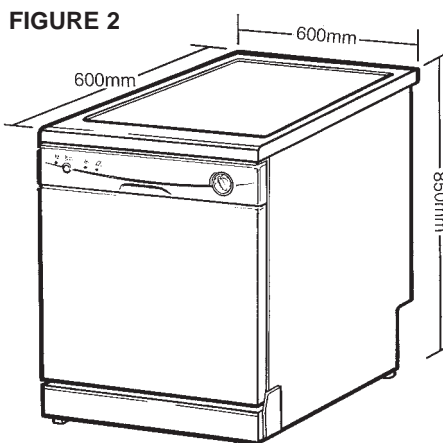
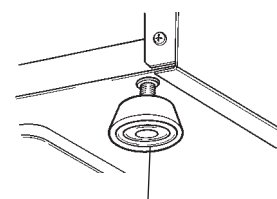

FIGURE 3



ADJUSTABLE FOOT

Provision for the connections

The connections for the appliance are shown in Figure 4 and Figure 5.

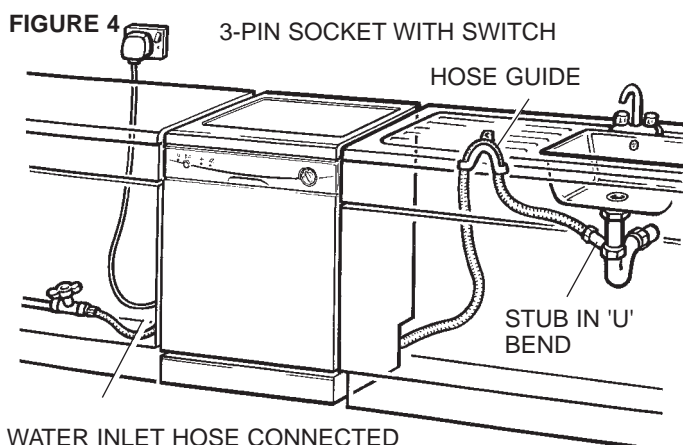

WATER INLET HOSE CONNECTED TO WATER PIPE VIA TAP

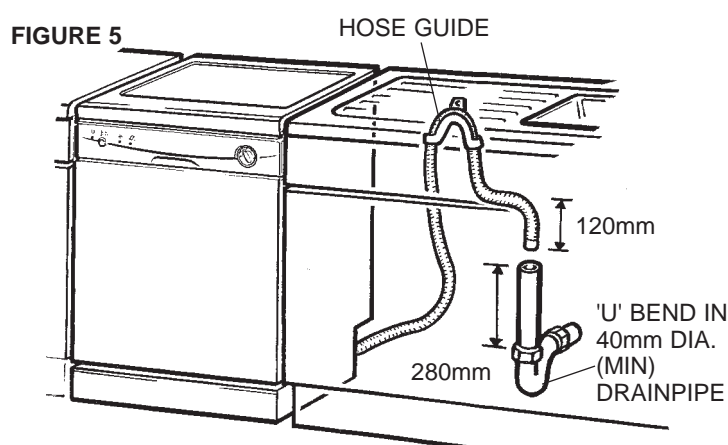

Connecting the drain hose to new drainpipe

Drain hose connection

When routing the drain hose, avoid bending or crimping it. Use the plastic hose guide that comes with the appliance ensuring that it is securely fastened to the wall.

You can either let the drain hose empty straight into the sink, connect it to a stub from the sink waste 'U' bend as shown in Figure 4, or to a new drainpipe of at least 40mm diameter with a 'U' bend as shown in Figure 5. If connecting to a new drainpipe, please note that the free end of the drain hose must be at a height of between 40–100cm and in a position where it is never immersed in standing water (Figure 4).

FIGURE 6

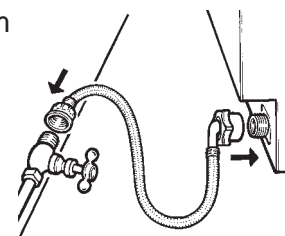

Water supply hose connection

The dishwasher must be connected to a water supply where the water temperature does not exceed 60°C otherwise the crockery may be damaged. The water supply pipe must be terminated to enable you to connect the dishwasher water inlet hose to it. If the pipe work is new, run water through the pipes to flush out any impurities and residues. Water inlet pressure must be above 0.4 bar (0.04MPa) but not exceeding 10 bar (1.0MPa).

Electrical connection

Connect the dishwasher to the electricity supply via a suitable 3-pin outlet socket. The socket must be earthed and have an ON/OFF switch (Figure 4).

Note: The socket and switch must be accessible when the appliance is installed.

Salt

Salt

The hardness of the water varies depending upon where you live. If hard water is used in the dishwasher, deposits will form on the dishes and utensils.

This appliance is equipped with a special softener that uses a salt specifically designed to eliminate limescale and minerals from the water.

Loading the salt into the dishwasher

Always use salt intended for use with dishwashers.

The salt container is located beneath the lower rack and should be filled as follows:

- Remove the lower rack and then unscrew and remove the cap from the salt container (Figure 7).
(If you are filling the container for the first time, fill it with water before adding the salt.)
- Place the end of the funnel (supplied) into the hole and introduce about 1.2kg of salt. It is normal for a small amount of water to come out of the salt container (Figure 8).
- Carefully screw the cap back on.

NOTE: The salt indicator light  on the control panel may stay illuminated until the salt has fully dissolved.

FIGURE 7

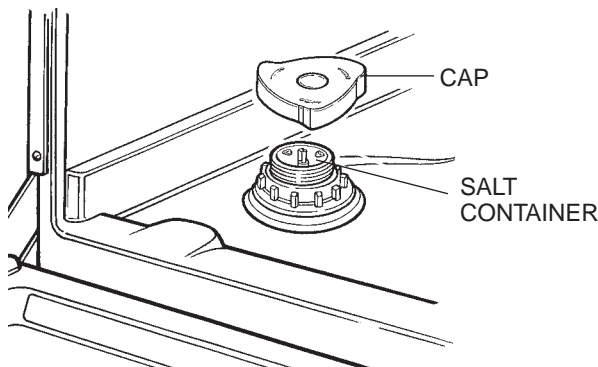
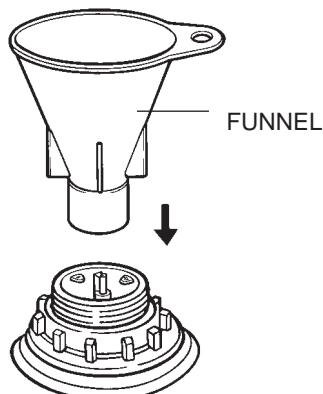

FIGURE 8



Periodically check and fill the container with fresh salt.

To prevent the formation of rust, load the salt just before beginning a wash cycle.

Adjusting salt consumption

The dishwasher is designed to allow you to adjust the amount of salt consumed, based on the hardness of the water in your area. This is intended to optimise and customise the level of salt consumption so that it remains at a minimum.

To adjust salt consumption, proceed as follows:

FIGURE 9

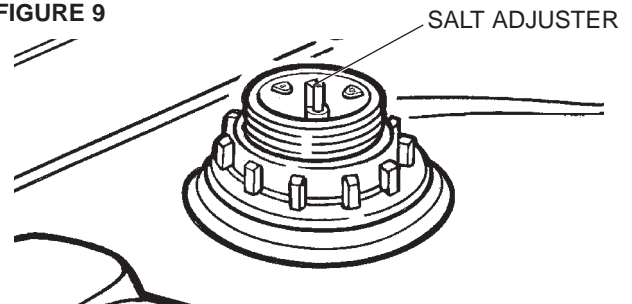

- Unscrew the cap from the salt container. The salt adjuster has an arrow on it (Figure 9).
- If necessary, rotate the salt adjuster in an anti-clockwise direction from the '-' setting towards the '+' sign, based on the hardness of the water being used.

Initially set the salt adjuster to the lowest setting '-'.

If cutlery and glasses are smeary after a wash turn the adjuster towards '+' .

Detergent and rinse aid

Detergent

Detergent specifically intended for use with dishwashers must be used. The dispenser must be filled before the start of each wash cycle following the instructions provided in the "Wash Cycle Table" (page 9). The detergent dispenser is located on the inside panel of the door.

Loading the detergent

Release the door by the catch, located in the door handle recess, and open the cover on the dispenser by pressing the latch. The detergent for the wash cycle should be placed in the compartment.

After the detergent has been placed in the dispenser, close the cover and press down until it "clicks" in place.

Please Note: Avoid getting any excess detergent on the edges of the dispenser compartment as this may foul the cover when closing.

Rinse aid

This product makes dishes sparkle and helps them to dry without spotting. The dispenser is located on the inside panel of the door and should be filled after every eighty wash cycles or when the low rinse aid indicator light ✨ comes on.

Loading the rinse aid

To open the dispenser, release the cap in an anti-clockwise direction and then pour in the rinse aid, making sure not to overfill.

The amount of rinse aid used for each cycle can be regulated by turning the dose adjuster, located beneath the cap, using a screwdriver. There are 6 different settings; the normal dosage setting is 3.

Important:

Proper dosage of the rinse aid improves drying. If drops of water remain on the dishes or spotting occurs, turn the dosage adjuster to a higher setting.

FIGURE 10

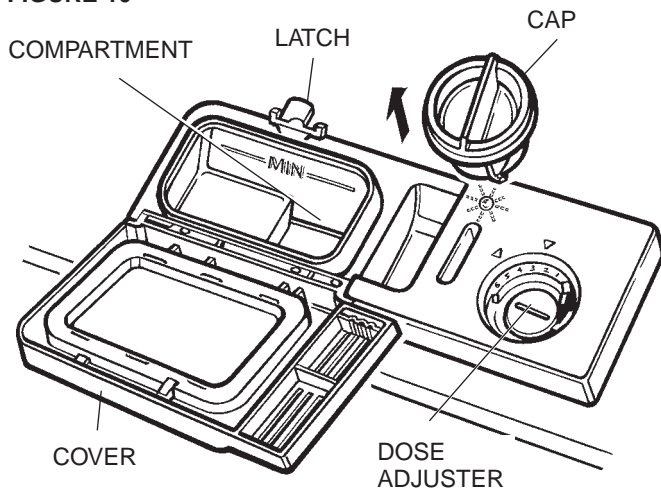

Loading the dishwasher

Before placing the dishes in the dishwasher remove the larger food debris. This prevents the filter from becoming clogged which can result in reduced performance.

If the pots and pans have baked-on food that is extremely hard to remove we recommend that they be allowed to soak before they are washed. This will eliminate the need for extra wash cycles.

Pull out the rack to facilitate loading the dishwasher (Figure 11).

How to use the lower rack

We recommend that you place the most difficult to clean items on the lower rack; saucepans, for example, lids, serving dishes and bowls.

It is preferable to place serving dishes and lids on the sides of the racks in order to avoid blocking the rotation of the top spray arm.

- Pots, serving bowls, etc. must always be placed face down.
- Deep pots should be slanted to allow the water to flow out.
- Cutlery should be placed in the cutlery basket with the handles at the bottom. If the rack has side baskets, the spoons should be placed individually into the appropriate slots. Especially long utensils and sharp knives should be placed in the horizontal position at the front of the upper rack.

Never allow forks or sharp utensils to protrude through the bottom of the cutlery basket obstructing the bottom spray arm.

FIGURE 11

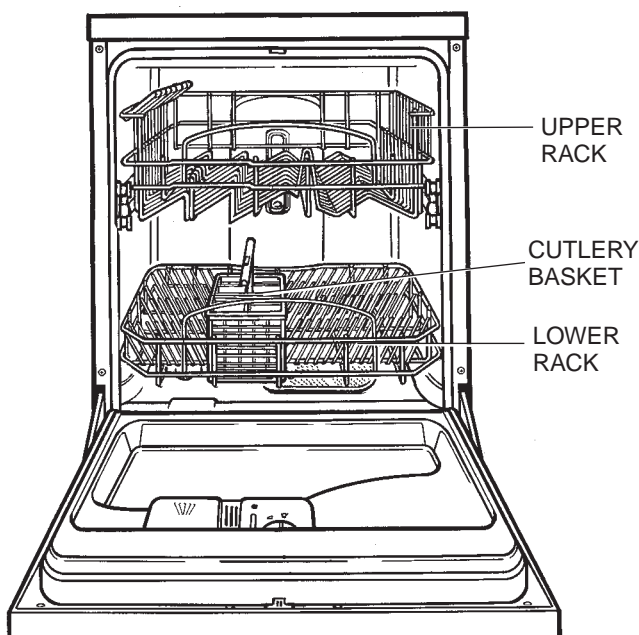

How to use the upper rack

The upper rack is designed to hold delicate and lighter dishware such as glasses, coffee and tea cups and saucers, as well as plates, small bowls and shallow pans (as long as they are not too dirty).

Position the dishes and cookware so that they are not in the way of the spray arms.

The upper rack can be adjusted for height by using the knobs located on the sides of the rack itself (Figures 12 and 13).

FIGURE 12

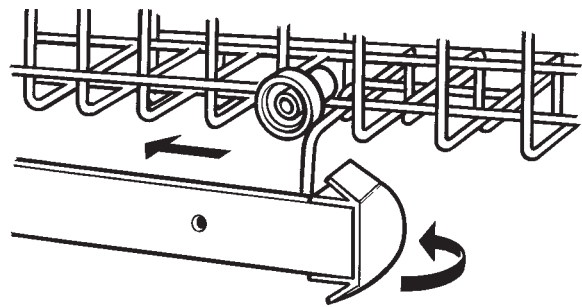
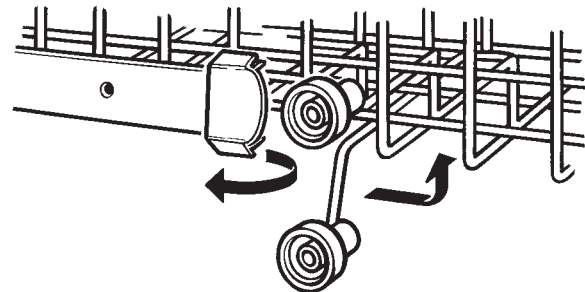
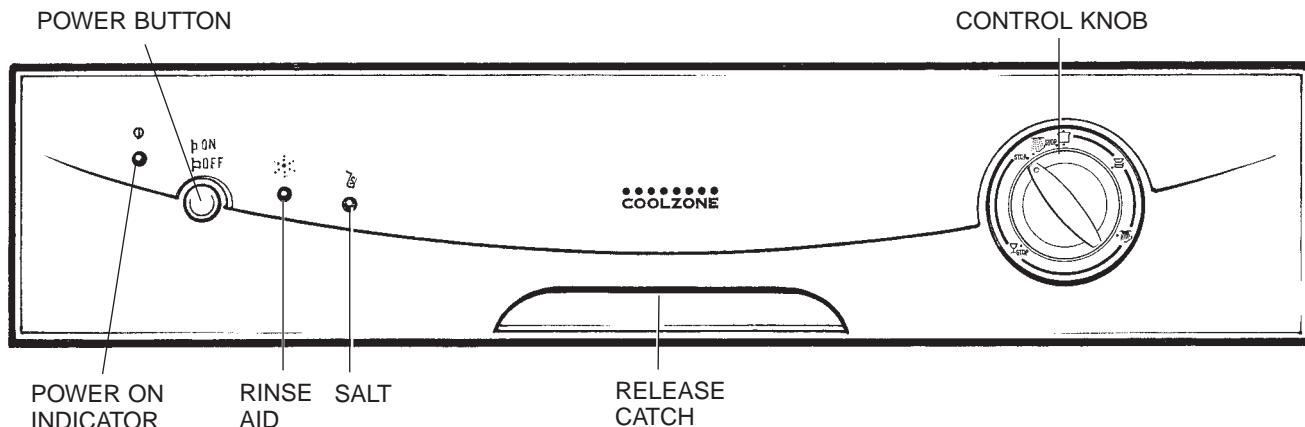

FIGURE 13



Control panel

FIGURE 14



Starting the dishwasher

FIGURE 15

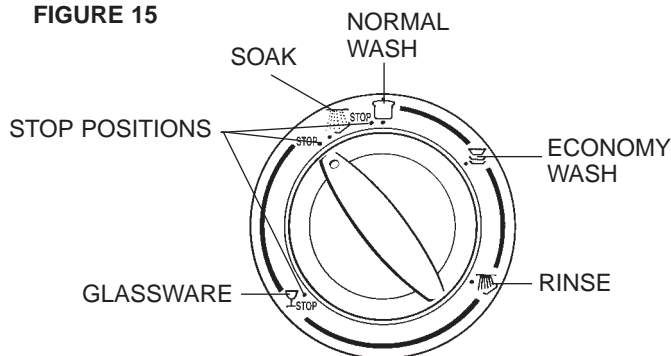

Setting and starting a wash cycle

Turn on the electricity and water supply to the dishwasher.

Ensure the dishwasher has been replenished with salt and rinse aid.

Choose the wash cycle you feel is most appropriate for the type of dishes that need washing (consult the Wash Cycle Table – page 9) by turning the control knob (Figure 15).

Close the door and press the Power button so the power indicator lights.

The machine fills with water and begins the wash programme.

Cancelling or modifying a cycle while underway

If the wash programme is modified after it has started the detergent may have already been released. Press the Power button, the Power Indicator light will turn Off.





Rotate the knob in a clockwise direction to the desired cycle setting. Reselect the desired cycle setting and press the switch back to On.

At the end of the wash cycle

At the end of the cycle the control knob stops turning and aligns with the Stop position on the control panel.

Wait a few minutes before removing the dishes so as to avoid handling them while still hot (when they are more susceptible to breakage) and to get better drying results.

Wash cycle table

Cycle	Cycle Selection Information	Description of Cycle	Detergent	Rinse Aid
 Normal wash (IEC-EN50242)	Normally dirty dishes, pots and pans. Standard daily cycle.	Pre-wash Wash 52°C Rinse 70° Drying.	25g	★
 Economy	Lightly soiled dishes, plates, glasses and pans	Wash 52°C Rinse 70° Drying.	22g	★
 Rinse	For dishes that need to be rinsed and dried only.	Rinse 70° Drying.		★
 Glassware	For lightly soiled loads such as glasses, crystal and fine china	Wash 52°C. Rinse 62°C Drying.	15g	
 Soak	Rinse dishes that you plan to wash later that day	Pre-wash		

Energy saving tips

- Run the dishwasher when it is fully loaded in order to save energy.
- Choose the right wash cycle. The choice of cycle depends on the type of dishware, cookware and utensils being washed and how dirty they are.
- Use the right amount of detergent. Using more detergent than necessary will not improve cleaning performance.

How to keep your dishwasher in shape

After every wash

After every wash it is advisable to turn off the water supply to the appliance and leave the door slightly ajar so that moisture and odours are not trapped inside.

Remove the mains plug

Before cleaning or performing any maintenance work on the appliance always remove the electric plug from the mains outlet socket. Do not run risks.

No solvents or abrasive cleaning products

To clean the exterior and rubber parts of the dishwasher, do not use solvents or abrasive cleaning products. Only use a clean cloth and soapy water.

To remove spots or stains from the surface of the interior use a cloth dampened with water and a little white vinegar, or a cleaning product made specifically for dishwashers.

When you go on holiday

When you go on holiday it is recommended that you run a wash cycle with the dishwasher empty and then remove the plug from the socket. Turn off the water supply and leave the door of the appliance slightly ajar. This will help the seals last longer and prevent odours from forming within the appliance.

Moving the appliance

If the appliance must be moved, try to keep it in a vertical position.

Door seal

One of the factors that can cause odours to form in the dishwasher is food that remains trapped in the door seal. Periodic cleaning with a damp sponge will help prevent this from occurring.

Cleaning and maintenance

Filter assembly

For best performance and results, the filters must be frequently cleaned.

The filters efficiently remove food residue from the wash water allowing it to be re-circulated during the wash cycle. For this reason it is a good idea to remove the larger food particles trapped in the filters after each wash cycle.

Release the coarse filter assembly from the main filter by turning it anti-clockwise (OPEN) to lift out.

Separate the two parts of the coarse filter by pulling them apart (Figure 16).

The main filter can then be lifted out and rinsed under running water.

The fine filter can then be removed for cleaning.

After the filters have been cleaned under warm running water replace them in the machine in reverse order.

Finally, turn the coarse filter clockwise (CLOSE) until it locks.

Never use the appliance without the filters.

Improper placement of the filters may damage the dishes and utensils etc.

FIGURE 16

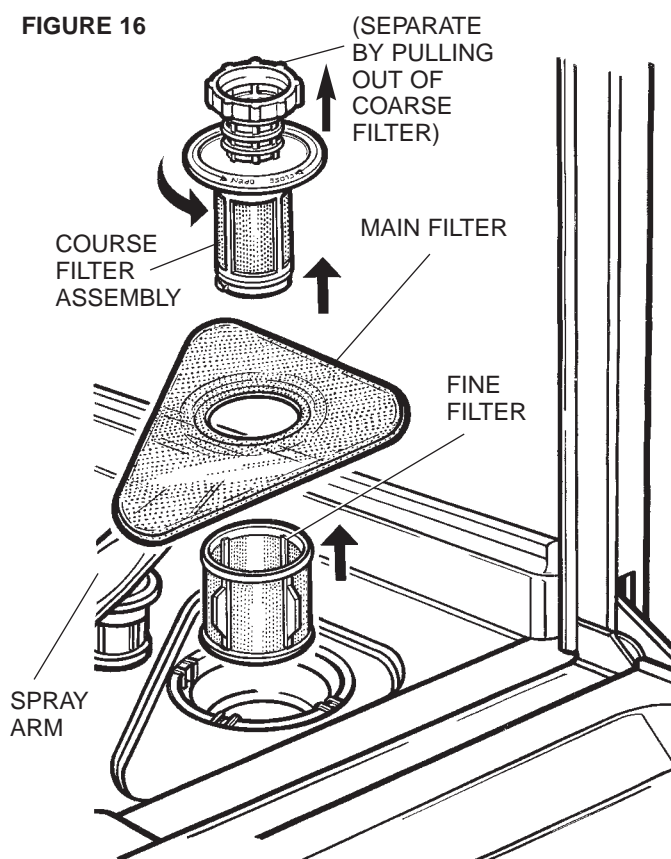

Cleaning the spray arms

It may happen that food particles become encrusted on the spray arms and block the holes. Check the spray arms periodically and clean them when needed. To release the bottom spray arm unscrew the nut clockwise. Lift off the arm. Clean the spray arm in soapy water and remove any debris from the holes with a soft brush. Replace the spray arm and secure by turning the nut anti-clockwise (Figure 17).

Cleaning the water inlet filter

Periodically clean the small water inlet filter located in the supply hose connector.

After turning off the water tap, unscrew the end of the water supply hose, remove the filter from the connector and clean it carefully under running water. Replace the filter and tighten the water supply hose back into position.

FIGURE 17

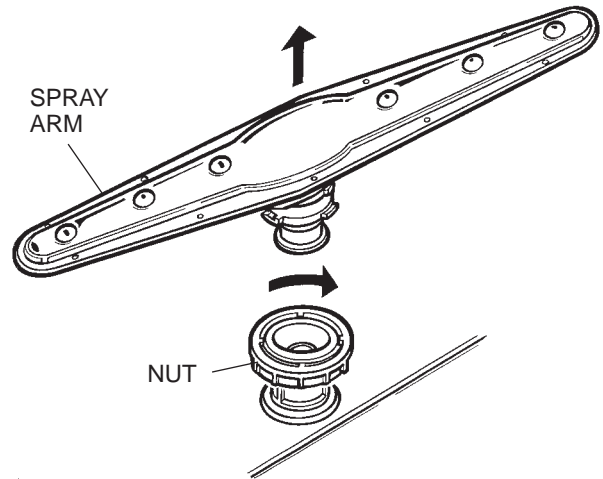

When not in use

If the appliance is to be turned off for a long period of time it is advisable to:

- ❖ Disconnect the unit from the mains supply.
- ❖ Empty the dishwasher.
- ❖ Clean and dry the interior.
- ❖ Leave the door open.

Troubleshooting

If the dishwasher is not functioning properly, before calling the Helpline, please check the following:

The dishwasher does not start

Have you checked whether:

- The plug is pushed firmly into the outlet socket.
- The mains electrical supply is switched on.
- The door is properly closed.
- The Power button is in the OFF position.
- The water supply is turned on.

The dishwasher does not take in water

Have you checked whether:

- The water to the appliance is turned on and the hose is properly connected.
- The mains water supply is turned on and is of sufficient pressure.
- The water supply hose is not crimped or bent.
- The water supply filter is not clogged (if fitted).

The dishes are not cleaned properly

Have you checked whether:

- The wrong programme has been selected.
- Dishwasher has not been loaded correctly.
- Spray arm is obstructed by utensils or dishes.
- Wrong quantity of detergent has been used.
- Rinse aid is empty.

The dishwasher does not drain properly

Ensure that the drain hose is not crimped or bent.

Note: The dishwasher is designed to detect an overflow. When this happens the circulation pump turns off and the drain pumps takes over. If this happens turn off the mains supply to the machine, isolate it from the water supply and contact the Helpline 0870 241 3029.

Limescale deposits or a white film forms on the dishes

Have you checked whether:

- The lid to the salt container is closed properly.
- The rinse aid dosage is correct.

If, despite all these checks the dishwasher still does not function and/or the problem persists, contact the Helpline 0844 871 0011 with the following information:

- The nature of the problem.
- The model Type Number (Mod...) and the Serial Number (S/N...). These are indicated on a plate located on the side of the inner part of the door.

Fuse and mains plug replacement

This product is supplied with a fitted plug which contains a 13A fuse. If you are simply replacing the fuse, you must use a 13A fuse which has been approved by ASTA to BS1362.

If the plug does not fit the socket or becomes damaged, a new plug must be fitted. Replace the original plug with the correct plug for your socket. If this is a 3-pin (square pin) 13A (BS1363) plug, you must make sure that it is fitted with an ASTA approved 13A fuse.

If another type of plug is used, it must be protected by a 15A fuse, either in the plug or at the distribution board.

1. Cut off the existing fitted plug.
2. The wires in the mains lead supplied with this appliance are coloured in accordance with the following code (Figure 18):

GREEN/YELLOW = EARTH (E)
BLUE = NEUTRAL (N) BROWN = LIVE (L)

This product must be earthed.

As the colours of the wires in the mains lead may not correspond with the colour markings identifying the terminals in your new plug proceed as follows.

The wire which is coloured GREEN or YELLOW/GREEN must be connected to the terminal which is marked with the letter E or \ominus symbol or coloured GREEN or YELLOW/GREEN.

The wire which is coloured BLUE must be connected to the terminal in the plug which is marked with the letter N or coloured BLACK or BLUE.

The wire which is coloured BROWN must be connected to the terminal which is marked with the letter L or coloured RED or BROWN.

3. Ensure that the connections are tight and that no loose strands are left out of the terminals.

IF IN ANY DOUBT CONSULT A QUALIFIED ELECTRICIAN.

If the mains lead becomes damaged consult a qualified electrician.

FIGURE 18

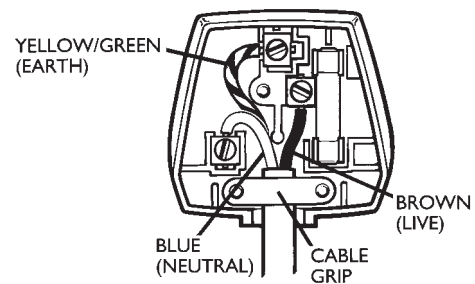

Specification

Dimensions: HxWxD cm:	85 x 60 x 58
Capacity:	12 standard place settings
Mains water pressure:	0.04-1.0MPa
Power supply	220/240V ~ 50Hz
Total power	1930W
Energy efficiency	A
Washing efficiency	B
Drying efficiency	B

Product specification may vary without prior notice.

Safety measures

Never try to repair the appliance or the electrical parts yourself. Any repair carried out by an unskilled person is dangerous and may affect the guarantee. Contact the Helpline below for assistance and advice.

Disposal of old dishwasher

Disposal of the appliance must conform with EU environmental regulations.

Make the appliance not usable by cutting off the mains lead and removing any door locks.

The appliance must be delivered to an authorised collection centre.

After sales service

This appliance is guaranteed for a period of 2 years from the date of purchase. Keep your purchase receipt with these instructions.

If the appliance fails to work properly during the 2 year period contact the:

Helpline on 0844 871 0011.

The appliance will be repaired (at the manufacturer's discretion) at no cost to you. If the guarantee has elapsed, you will be given a quotation for any repairs or parts required.

This appliance/fitting is marked according to the European directive 2002/96/EC on Waste Electrical and Electronic Equipment (WEEE). By ensuring this product is disposed of correctly, you will help prevent potential negative consequences for the environment and human health, which could otherwise be caused by inappropriate waste handling of this product.

The symbol on the product, or on the documents accompanying the product, the Crossed Out Wheelie Bin symbol, indicates that this appliance/fitting may not be treated as household waste. Instead it shall be handed over to the applicable collection point for the recycling of electrical and electronic equipment. Disposal must be carried out in accordance with local environmental regulations for waste disposal. For more detailed information about treatment, recovery and recycling of this product, please contact your local authority, your household waste disposal service or the retailer where you purchased the product.

