

COOLZONE[®]

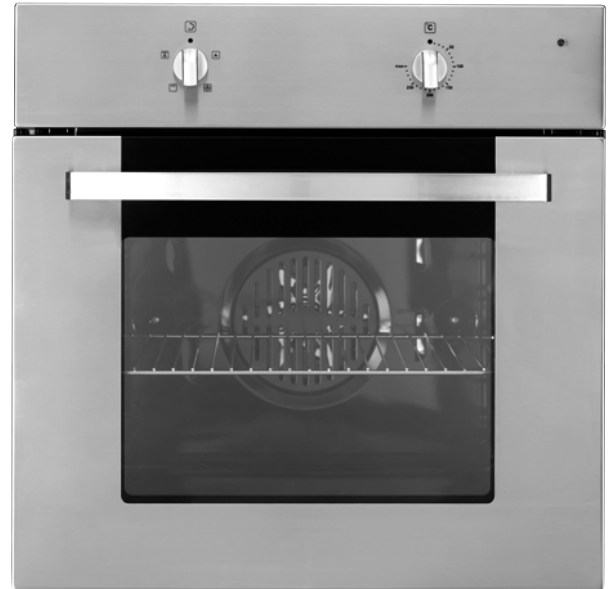

Stainless Steel Built-in 4 Function Fan Oven and Electric Hob pack

CZ55525

INSTALLATION AND OPERATING INSTRUCTIONS

These products may differ from the ones illustrated but the installation and operation procedure remains the same

Contents

Introduction	3
Unpacking	3
Before installation	3
Combined or Separate installation	4
Location	4
Housing dimensions	5
Electricity supplies	6
Hob cut-out	7
Hob electrical connection	8
Fitting the Hob	9
Fitting the Oven	10
Oven and hob preparation	10
Safety notes	11
Using the hob	12
Fire safety	12
Using the oven	13
Using the grill	14
Care of the hob	15
Cleaning the hob	15
Cleaning the oven	15
Cleaning the glass oven door	16
Changing the oven lamp	16
Mains lead replacement	17
Plug replacement	17
For best cooking results	18
Troubleshooting guide	19
Customer Helpline	Back page
Specification	Back page
Safe product disposal	Back page

Introduction

This quality oven and hob have been designed to provide trouble-free service provided they are installed and maintained correctly. Both units are for domestic use only.

Please read these instructions carefully before installing or using your appliances. It is advisable to keep your purchase and installation receipts with these instructions in a safe place for future reference. Included is some important safety information, guidelines and recommendations to enable you to safely use your oven and hob.

These appliances have been tested and certified to meet all applicable UK electrical and safety standards.

The hob must only be installed by a qualified electrician. The appliances must only be repaired by qualified electricians or authorised service personnel. If not repaired properly you could be putting yourself and others in danger. It will also invalidate the guarantee.

If you have any questions or need assistance please telephone the Helpline on 0844 871 0011.

When contacting the Helpline please have model numbers to hand. The oven's model number is shown on the data label which is visible by opening the door. The hob's number is shown on the data label on the underside of the casing.

Unpacking

Carefully remove all the packaging and lift out the appliances and accessories, watching out for sharp edges.

Remove any tape or packing material used for transit, including any material inside the oven.

Check the appliances for any damage. If either unit has been damaged **do not use it** and contact the retailer from whom the appliance was bought.

Retain the packaging until the units have been installed, removing it from the area of installation and keeping it out of the reach of children.

Dispose of all the packaging in accordance with your local authority guidelines as well as any old appliance that is being replaced – see safe oven disposal section.

Before installation

Before any installation work can be carried out a number of requirements must be met.

Make sure that you or your installer are familiar with all the relevant building and fire regulation requirements before choosing the location of your appliance.

This appliance must be installed in accordance with the instructions to validate the guarantee.

Refer to the "Location" section for minimum clearances and safe placement of your appliances

Combined or Separate Installation

There are two installation options for this oven and hob pack:

1. Oven and hob combined in a single housing unit under a worktop, as shown in Figure 1.
2. Oven and hob installed separately into individual housing units as shown in Figure 2.

Before deciding on the position of your appliances, please read the 'location' and 'housing dimensions' sections that follow..

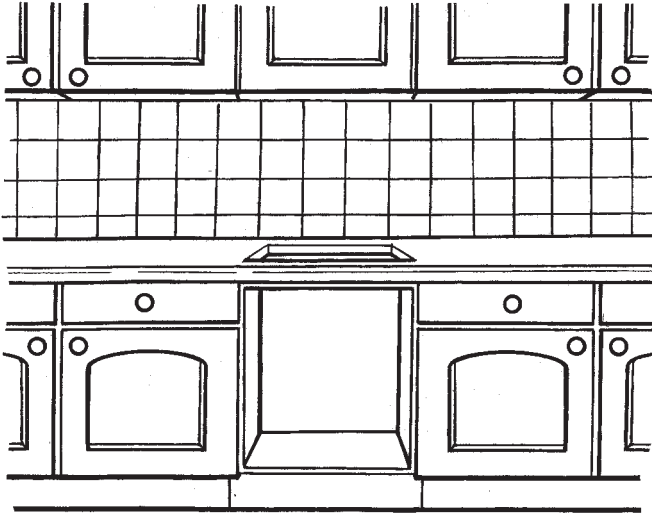

Figure 1 - combined installation

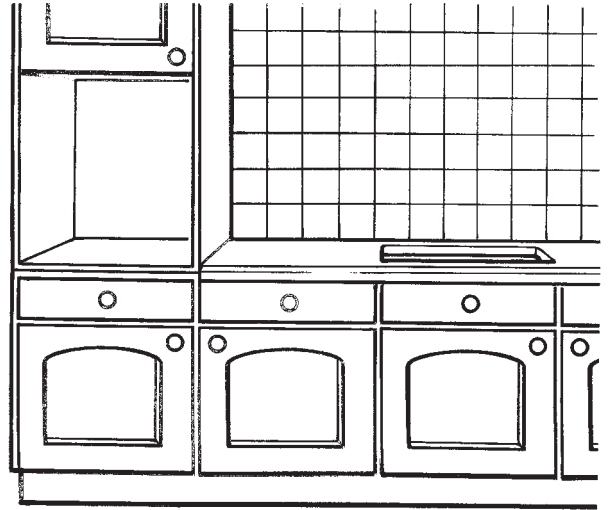

Figure 2 - separate installation

Location

Avoid installing the oven or hob next to a fridge, freezer or boiler.

It is best if the hob is surrounded by work surface, giving safe space to rest a hot pan and space to turn handles so that they do not protrude into the walkway or become too hot over a neighbouring hotplate.

Hob clearance space

Certain minimum clearances must be allowed for when planning the unit's location (Figure 3):

Beneath the work surface, allow the required clearance for appliances or units to be installed below.

There should be an open space above the hob to allow kitchen odours to disperse. A cooker hood may be installed to either absorb or extract the odours. The distance between the hob and the hood must not be less than **650mm** (Figure 3).

The distance between the hob and the back edge of the worktop should be no less than **50mm** (Figure 3).

Leave adequate clearance between the hob and adjacent cupboards (no less than **150mm**.)

To ensure that the hob is properly supported, the distance between the hob cutout and the worktop end should be no less than **60mm** (Figure 3).

Ensure a gap of not less than **400mm** between the hob surface and overhanging cupboards.

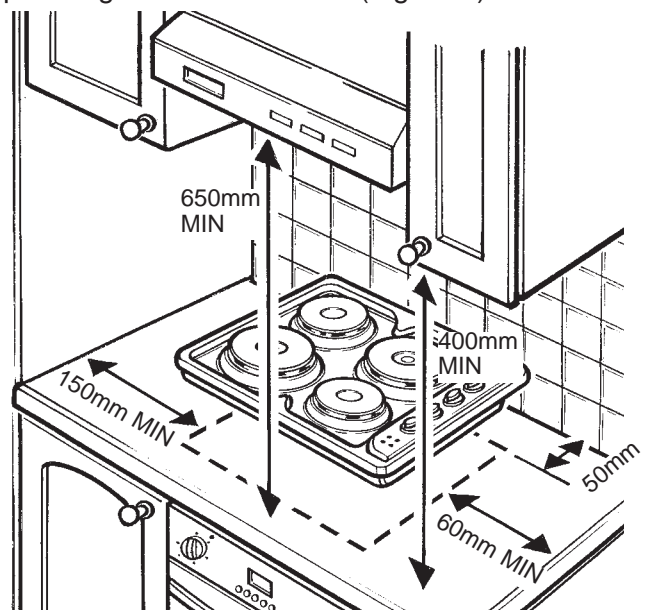

Figure 3 - minimum clearances (hob)

Location continued

Safety Requirements

Ensure that the surrounding material is heat resistant and non-combustible.

The electricity supply must be routed near to the installation (see page 6).

There must not be any plugs, wires or sockets in the wall directly above or behind the hob.

Housing dimensions

Before starting the installation process, it is important to check that the appliances will fit into the units they will be housed in. **These dimensions apply equally to combined or separate installations.**

Hob

The hob must be installed into a work surface, fitted with an opening cut into the surface so that the top plate sits flush with the surface. It can be fitted above the oven, or separately, but in either case It is best positioned directly above a 600mm wide fitted kitchen cabinet (Figure 4).

Oven

The oven can be installed into a housing unit of the correct dimensions, either below a worktop, or into a separate floor standing unit. (Figure 5).

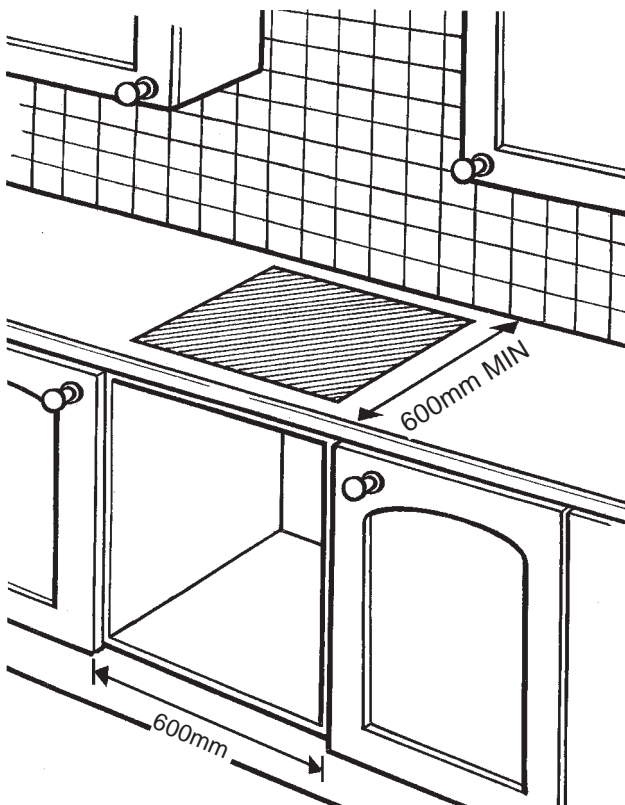

Figure 4 - hob housing dimensions

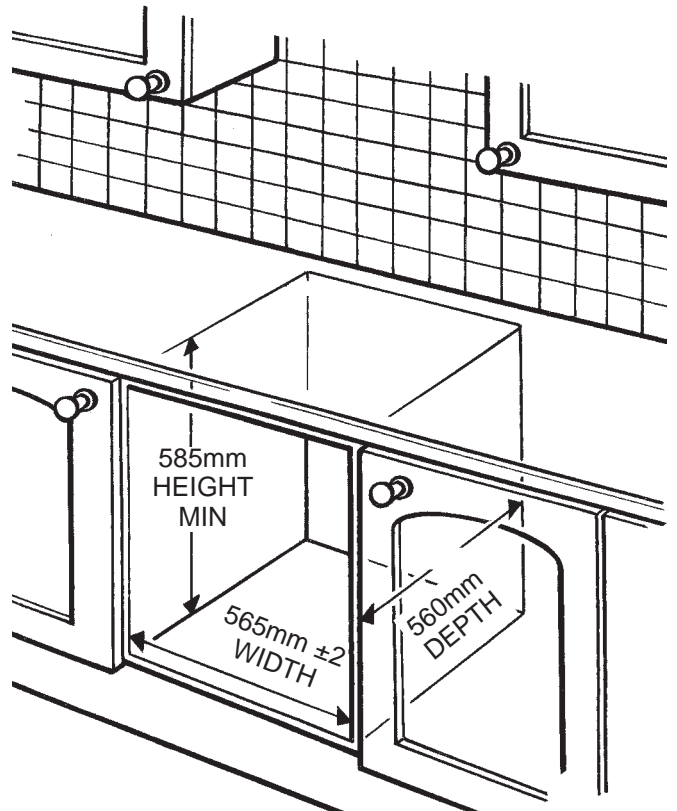

Figure 5 - oven housing dimensions

Electricity supplies

Once satisfactory locations have been established, the electrical supplies to the appliances must be arranged beneath the work surface.

Hob only

The supply should be from a 45 amp fused spur, with an isolator switch installed above the work surface and to one side of the unit, in case of an emergency (Figure 6). The isolator switch must have working contacts 3mm apart.

The mains supply cable from the isolator to the hob must be rated for the maximum power consumed by the hob (specified on the data plate).

The supply cable must be long enough to reach the far side of the hob, plus an extra 750mm of slack to allow for removal and servicing. The supply cable must be routed away from hot surfaces.

Hob and oven (combined installation)

If the appliances are combined in the same unit, both appliances can be wired into a the same fused spur (Figure 6).

Oven only

A 3-pin plug socket with an earth contact, if one does not already exist, should be installed on the wall behind the oven, and a suitably rated isolator switch should be installed to one side of the unit, above the work surface or at similar height, for easy access in case of emergency (Figure 7).

This installation must be carried out in accordance with current I.E.E. Wiring Regulations and Building Regulations (Part P).

If in any doubt consult a qualified electrician

The mains voltage must correspond exactly to that which is specified on the data plates.

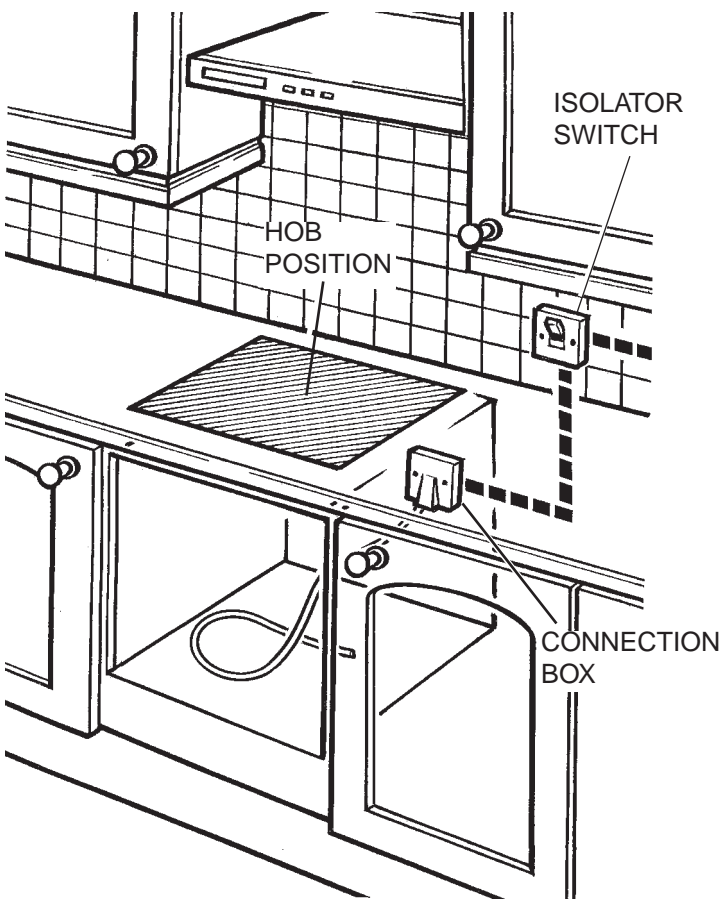

Figure 6 - electricity supply (hob / combined)

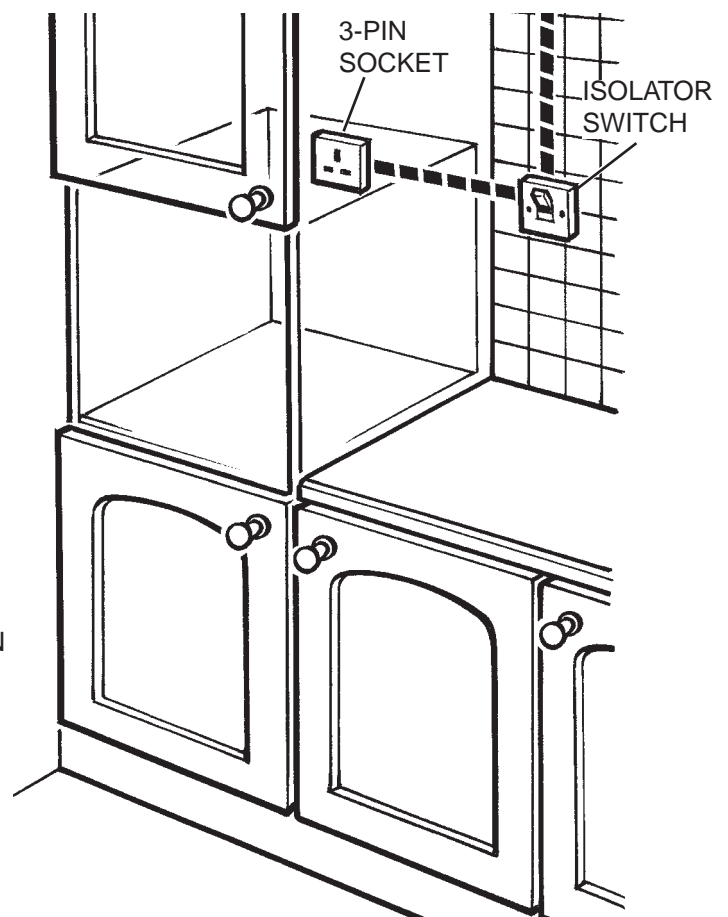

Figure 7 - electricity supply (oven only)

Hob cut-out

PLEASE NOTE: If the hob and oven are to be installed into a single housing unit (combined installation), the hob must be fully installed before the oven can be installed.

A cut-out for the hob can be made onto the work surface as follows:

1. Cover the approximate area for the cut-out with masking tape.
2. Position the unit face down on the surface, ensuring that the top plate is exactly centred above the 600mm kitchen cabinet supporting the worktop, and that you have the correct clearance spaces around the hob.
3. Draw round the hob to mark the space that will be taken up by the top plate on the work surface.
4. Lift the unit away to a safe distance, and check that the outline produced corresponds with the hob dimensions (585 x 500) in Figure 8.
5. Mark the cut-out (565 x 480 as in Figure 8) onto the masked work surface. The cut-out line should be in a central position so that there is an even space of 10mm between the cut-out shape and the hob outline, all the way round (Figure 9).
6. Ensure that no pipes, hoses or wires are present as obstructions below the worktop, then cut the opening into your work surface exactly where you have marked the cut-out shape (Figure 9).
7. Remove the tape and ensure the area is clean and free of dust and debris.
8. Carefully lift the hob and place it into the cut-out opening to check for a good fit.

Do not clamp the unit into place yet as arrangements must be made to connect the unit to its electricity supply.

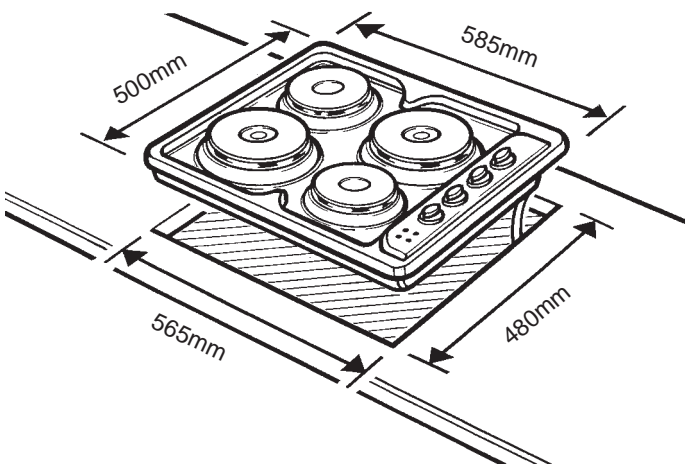

Figure 8 - cut-out dimensions

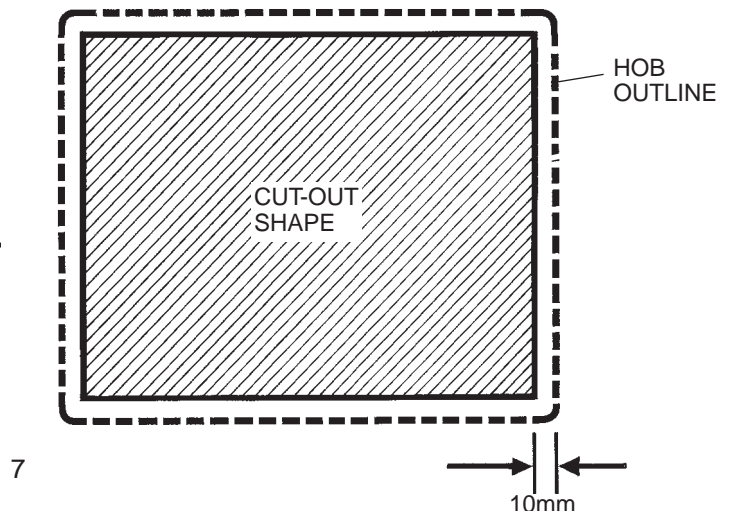

Figure 9 - marking the cut-out

Hob electrical connection

The hob must be properly connected to the mains supply by a qualified electrician according to current safety regulations.

This appliance must be earthed.

1. Release the cover by removing the cover screws (Figure 10).
2. Loosen the cable clamp (Figure 10).
3. Connect the mains supply cable to the terminal block on the hob using the following colour code (Figure 11):
 - The green or yellow/green (earth) wire should be connected to the corresponding yellow/green wire on the terminal block or marked E or ⊕.
 - The blue or black (neutral) wire should be connected to the corresponding blue wire on the terminal block or marked N.
 - The brown or red (live) wire should be connected to the corresponding brown wire on the terminal block or marked L.
4. Secure the cable clamp. Check the cable terminals for tightness and ensure that the terminal links are in place, then close the cover over the terminal block (Figure 10).

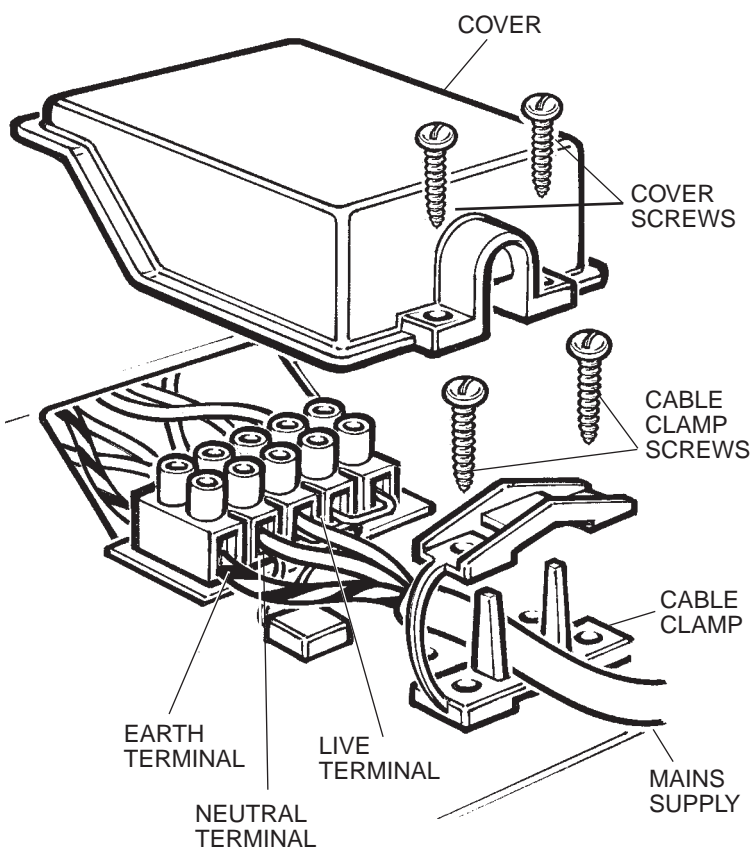

Figure 10 - connection box

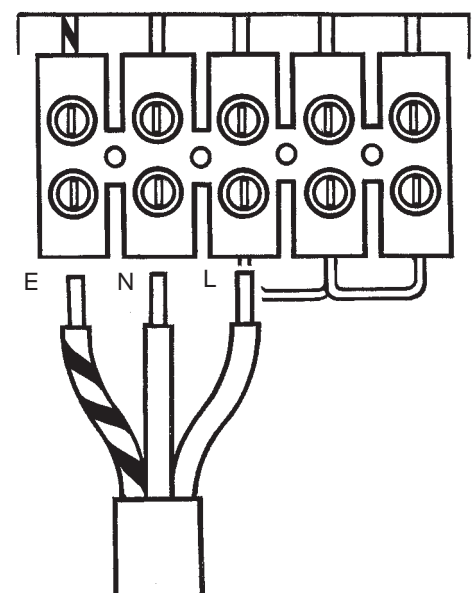

Figure 11 - terminal block

Fitting the hob

Once the hob has been connected to its electricity supply, it can be fitted into position as follows:

1. Place the hob upside down on an adjoining surface.
2. Fit the clips onto the hob by sliding the notched end into the slot and loosely screwing the screw into the screw-hole (Figure 12). Turn the clips round so that they are in line with the hob (Figure 13).
3. Make sure that the underside edge of the hob is clean and dry.
4. Stick the foam sealing strip around the underside of the hob, 5mm in from the edge, removing the adhesive backing as you go (Figure 13). When the sealant has been stuck round all four sides and meets up with itself, trim off any excess sealing strip, leaving a neat join.
5. You may wish to add a thin bead of clear silicone sealant around the underside edge of the hob.
6. Turn the hob over and place it in centralised position in the cut-out hole, making sure that the electricity supply cable is clear of the base of the hob and any other possible heat source.
7. Turn the clips, making sure that the clips grip the worktop, and then tighten the screws (Figure 14).
8. If necessary, finish the bead of sealant with a suitable tool while it is still workable.

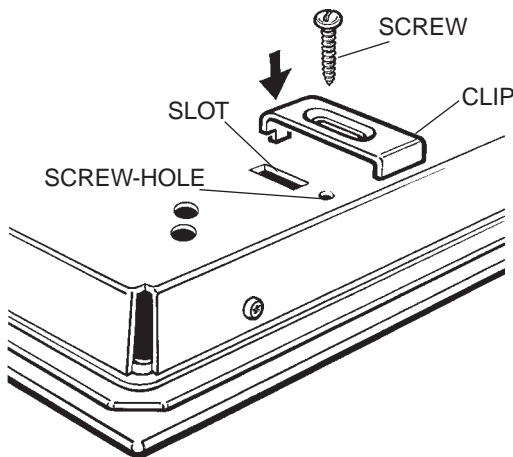

Figure 12 - preparing the clips

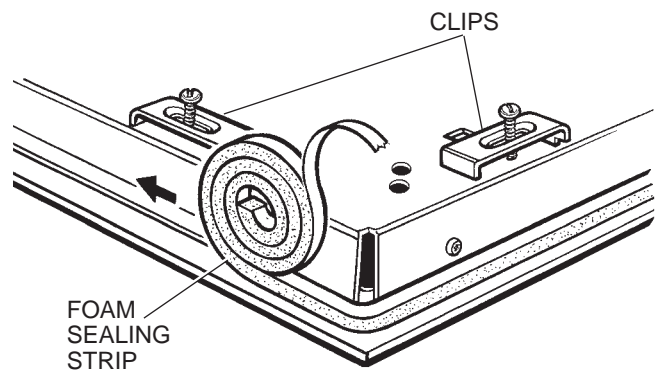

Figure 13 - applying sealing strip

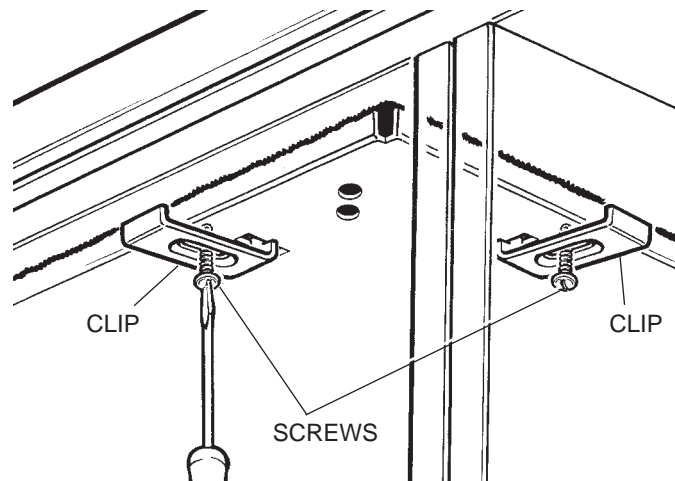

Figure 14 - fixing to worktop

Fitting the oven

Before installing the oven in its housing, insert the mains plug into the mains outlet socket. Avoid trapping the mains cable between the appliance and the housing and ensure it is routed away from hot surfaces.

Place the oven into the housing unit and adjust its position until it is level, making sure it aligns with any adjacent units, drawers, and cupboard doors (Figure 15).

When correctly positioned, drill the unit and secure the appliance in place with two fixing screws (Figure 16).

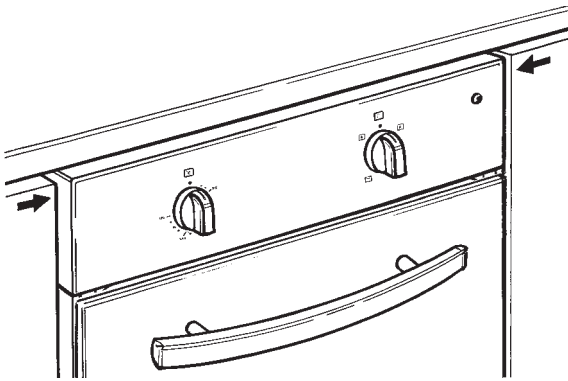

Figure 15 - centralising the oven

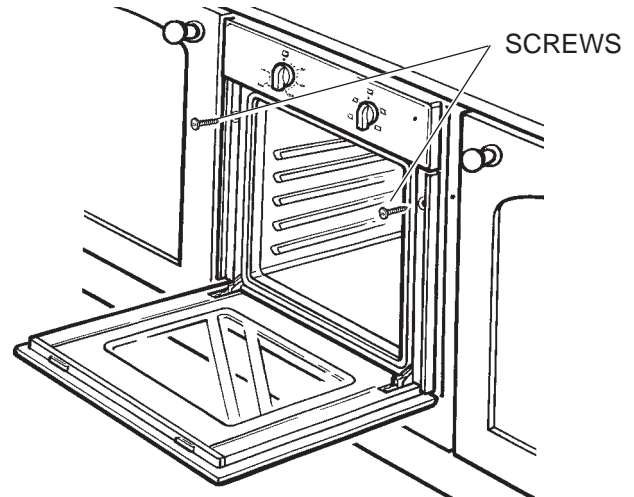

Figure 16 - installing the oven

Oven and hob preparation

1. Remove any stickers and glue from the surfaces of the oven and hob with warm water and washing-up liquid.
2. When using for the first time, turn on the hot plates, one at a time, and set the temperature selector knob to position '6'. Leave them on for about 5 minutes.
This will burn off the protective film covering the plates.
3. When the plates are cool, wipe them with a soft dry cloth.

PLEASE NOTE: When using for the first time the oven may smell for a short time while burning off dust and manufacturing residues from the heating elements. This is normal and does not indicate a fault with the oven.

Safety notes



Hob

- Allow the hob to cool before cleaning.
- Make sure you understand what the controls do before using the hob.
- Always turn off the hotplates when not in use
- Always be careful when operating the hob and take care to avoid touching the hotplates
- Ensure that the cables of other household appliances used near the hob are away from the hotplates
- Place pans centrally on the hotplates and position them so that the handles cannot accidentally be caught or become heated by other hotplates
- Keep the hob clean as a build up of grease or fat from cooking can cause a fire.
- Never leave children unsupervised where the hob is installed as the appliance will get hot during and after use.
- Never allow anyone to sit or stand on the hob or the surrounding work surface.
- Never store chemicals, food stuffs or pressurised containers in cabinets above or next to the hob.
- Never place flammable or plastic items on or near the hob.
- Never use the hob as a room heater.
- Never use the hob to dry clothes and tea-towels or for any other purpose than the cooking of food.

Oven

- Allow the oven to cool before cleaning.
- Make sure you understand what the oven controls do before using the oven.
- Always turn the oven controls to the OFF position when the oven is not in use.
- Before removing cooked food from the oven open the door carefully to allow any heat to disperse.
- Use dry oven gloves when removing items from the oven.
- Be careful when operating the oven and take care to avoid touching hot elements inside the oven.
- Ensure that the cables of other household appliances used near the working oven are away from its hot elements. Ensure also that the cables are not trapped by the oven door.
- Keep the oven door closed when the oven is not in use.
- Keep the oven clean as a build up of grease or fat from cooking can cause a fire.
- Keep any ventilation holes clear of obstructions.
- Never leave children unsupervised where the oven is installed as the appliance will get hot during and after use.
- Never allow anyone to sit or stand on any part of the oven.
- Never heat up unopened food containers as pressure can build up causing them to burst.
- Never store chemicals, food stuffs or pressurised containers in cabinets above or next to the oven.
- Never use the oven as a room heater.
- Never dry clothes or place other items on the oven door.
- Never line any part of the oven cavity with aluminium foil.

Using the hob

Before using your hob for the first time:

Read the operating and safety instructions thoroughly

If you have not already done so, follow the steps in the “Preparation” section on page 7 to burn off the protective film covering the plates.

Before switching on a hotplate, make sure that the selector knob you are using corresponds to the hotplate you wish to switch on (Figure 17).

WARNING: If any of the hotplates become cracked, disconnect the appliance from the mains supply and do not use until repaired by a qualified technician.

The hotplates

The hotplate power is regulated with a 7 position temperature selector knob. The control allows for the efficient transfer of heat to the cooking pan. (Figure 18).

The selector knob can be turned in both directions:

- Anti-clockwise to increase heat
- Clockwise to decrease heat

There are symbols ● to 6 marked on the knobs (Figure 18). These correspond to the heat setting of the hotplate.

- 6 is the highest setting
- ● is OFF

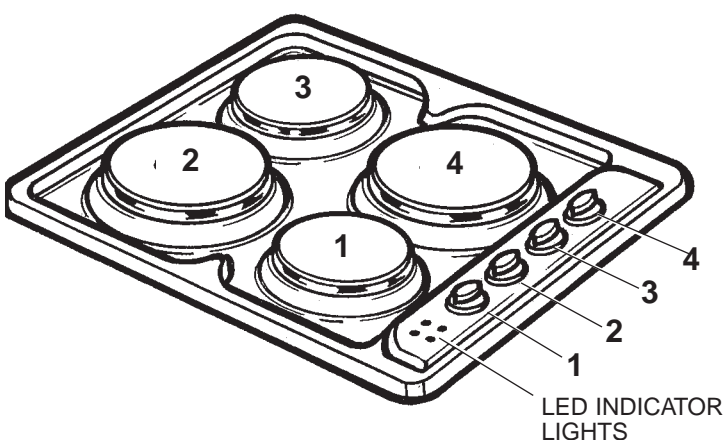

Figure 17 - hotplate controls

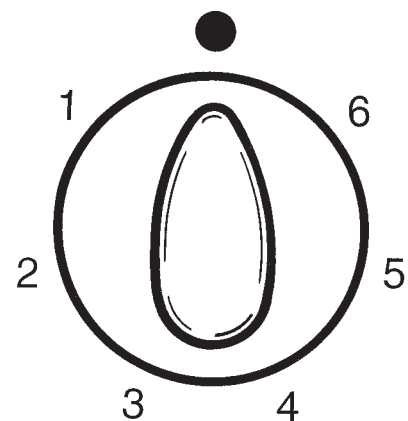

Figure 18 - control knob



Fire safety

Never fill a deep fat frying pan more than 1/3 full of oil

Do not leave unattended while cooking!

In the event of a cooking pan fire:

1. Turn off the hob at the electricity wall socket
2. Cover the pan with a fire blanket or damp cloth
3. Leave the pan to cool for at least an hour before you try to move it.

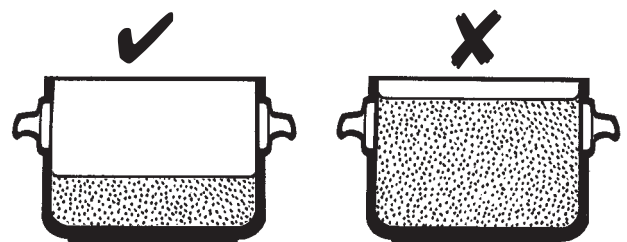

Never use a fire extinguisher to put out a pan fire (the force of the extinguisher could tip the pan over.)

Never use water to put out oil or fat pan fires.

Using the oven

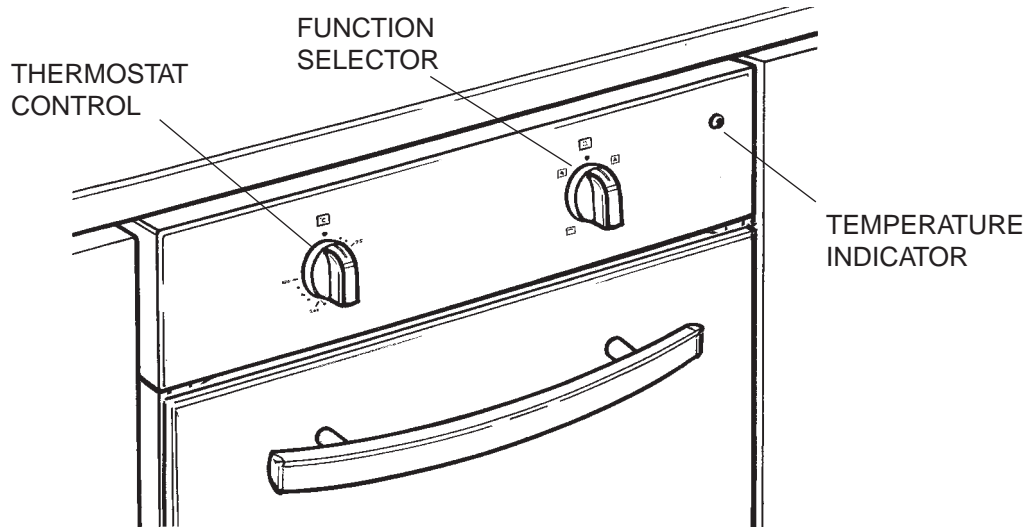

Figure 19 - controls

The oven is fan assisted and evenly distributes the heat throughout the oven. This may reduce the cooking times compared with a conventional oven so always read the cooking instructions on the packaging when cooking convenience food.

It is recommended to preheat the oven for a few minutes or wait until the temperature indicator goes off before placing food in the oven for cooking.

Be careful when using aluminium foil. Do not cover the sides of the oven, the shelf or oven interior. If wrapping food in foil the cooking time may increase.

Thermostat Control

The thermostat control determines the temperature inside the oven during cooking. Turn the control knob clockwise to align the cooking temperature with the marker on the control panel. During cooking the thermostat will maintain the set temperature.

The temperature can be set between 50°C and 250°C.

Function Selector

There are 4 functions and OFF.

Turn the control selector so that the symbol on the selector aligns with the marker on the control panel. The interior oven light illuminates when a function is selected..



Defrost setting

This function operates the fan without the oven heating up. This is suitable for defrosting frozen food.



Top heating element (grill)

Use this function for grilling or top oven heat which is suitable for browning food.



Fan assisted cooking

Fan assisted cooking uses the fan and circular heating element to evenly distribute the heat throughout the oven.



Fan assisted grill

Select this function to use the fan and grill together.



OFF position.

Using the grill

IT IS IMPORTANT TO CLOSE THE OVEN DOOR WHEN GRILLING FOOD.

Move the shelf to the first or second position from the top.

Select the symbol  on the control selector.

Turn the thermostat control between 50°C and 250°C and preheat the element for five minutes.

Place the food in the middle of the grill pan and position the pan so the food is near but not touching the top element.

Do not line the grill pan with aluminium foil or wrap food items with foil before placing under the grill. Aluminium foil has a high reflectivity which can damage grill elements.

When fitting the handle, hook the handle over the edge of the grill pan and through the wire rack at a central point along the grill pan edge, (Figure 20). Lower the handle fully down to fit.

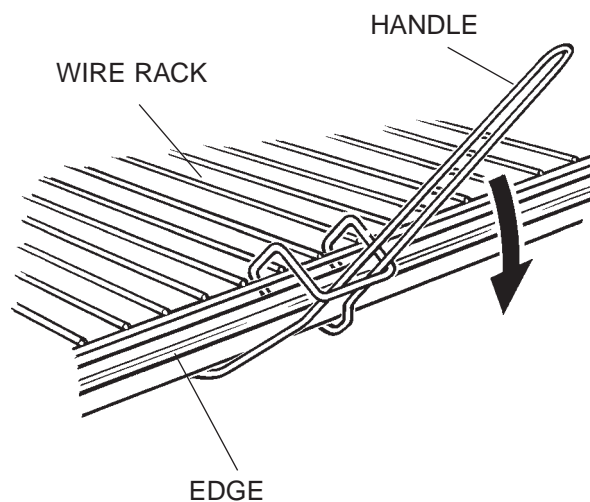

Figure 20 - fitting the handle

Care of the hob

Never turn the hotplate on before placing a pan on it (except when first used).

Never sprinkle cold water onto a heated hotplate.

Do not allow spills to be burnt onto the hotplate since baked stains are very difficult to remove.

Keep the hotplates clean. A dirty hotplate does not transfer heat efficiently.

Avoid placing wet pans on the hotplates.

Never use the hot plates for preparing foods wrapped in aluminium foil or in plastic pans, or place any plastic trays etc. on the hotplates.

Cleaning the hob

WARNING: Switch off the hob at the mains isolator switch before cleaning.

Clean the hob regularly to maintain its working condition and appearance. Clean it when it is cold.

When cleaning the hob, do not use harsh abrasives, caustic cleaners or sharp objects.

All stainless steel parts should be cleaned with a non-abrasive cleaning liquid on a soft cloth.

Clean the hotplates with a damp sponge and then dry them by turning them on for a few seconds. To maintain their appearance, apply a commercially available grease intended for hotplates.

The hotplate trim rings can be cleaned with products intended for stainless steel. The rings can become yellowed as a result of heating. This is normal.

If a hotplate is to be out of use for a long time, apply the special grease periodically.

Cleaning the oven

Before cleaning the oven, wait for it to cool down.

It is best to clean the bottom of the oven after every use and not allow the food or spots of oil to remain and become permanent stains.

Wash surfaces in warm soapy water.

For stubborn marks on glass surfaces, a mild cream cleaner can be used. Dry parts with a soft cloth.

For the interior surfaces in the oven use normal oven cleaners but always read the manufacturer's instructions on how to use them.

Do not use caustic paste, abrasive wire, powders or hard instruments to clean any part of the appliance.

Cleaning the glass oven door

Ensure the oven door is cool before cleaning. Removal of the door makes it easier to clean the door, the door surround and the seals.

To remove the door proceed as follows:

1. Open the door fully.
2. Raise one hinge clip and rotate it towards you as far as the stop (Figure 21). Repeat the procedure with the second hinge clip on the other side of the door.
3. Raise the door gently until it comes to rest against the hinge clips.
4. Grip the edges of the door and lift the door clear of the catches in the hinge openings.
5. When cleaning the door, take care not to move the clips from their position.
6. Once cleaning is complete, lift the door and slide the hinges into the hinge openings.
7. Engage the slots on the hinges with the catches in the hinge openings.
8. Check that the weight of the door is fully supported on the hinges.
9. Lower the door and raise the hinge clips, then return them away from you and back to their starting positions.
10. Check that the seal is in place then close the door. Make sure that the inner face of the door meets and shuts against the seal all around.

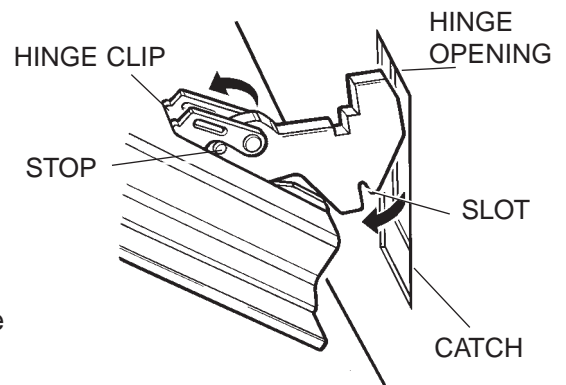

Figure 21 - removing the oven door

Changing the oven lamp

Wait for the oven to cool.

Unscrew and remove the diffuser. Unscrew the lamp from the lampholder. Replace lamp and diffuser (Figure 22).

The replacement lamp must be of the same type, voltage and wattage (15W SES 300°C).

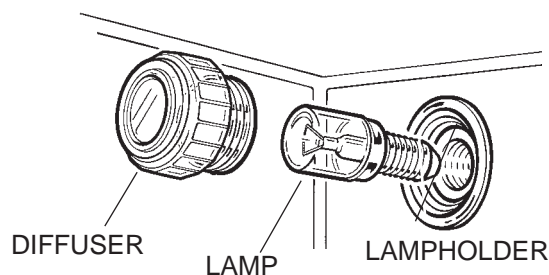

Figure 22 - changing the lamp

Mains lead replacement

Do not attempt to repair or replace the mains connecting cable yourself, consult a qualified electrician.

Plug replacement

The oven is supplied with a fitted plug which contains a 13A fuse. If you are simply replacing the fuse, you must use a 13A fuse which has been approved by ASTA to BS1362.

If the plug does not fit the socket or becomes damaged, a new plug must be fitted. Replace the original plug with the correct plug for your socket. If this is a 3-pin (square pin) 13A (BS1363) plug, you must make sure that it is fitted with an ASTA approved 13A fuse. If another type of plug is used, it must be protected by a 15A fuse, either in the plug or at the distribution board.

1. Remove the existing fitted plug.

2. The wires in the mains lead supplied with this appliance are coloured in accordance with the following code:

GREEN/YELLOW = EARTH (E) BLUE = NEUTRAL (N) BROWN = LIVE (L)

This product must be earthed

As the colours of the wires in the mains lead may not correspond with the colour markings identifying the terminals in your new plug, proceed as follows.

The wire which is coloured GREEN or GREEN/YELLOW must be connected to the terminal which is marked with the letter E or ⊕ symbol or coloured GREEN or GREEN/YELLOW.

The wire which is coloured BLUE must be connected to the terminal in the plug which is marked with the letter N or coloured BLACK or BLUE.

The wire which is coloured BROWN must be connected to the terminal which is marked with the letter L or coloured RED or BROWN.

3. Ensure that the connections are tight and that no loose strands are left out of the terminals.

IF IN ANY DOUBT CONSULT A QUALIFIED ELECTRICIAN.

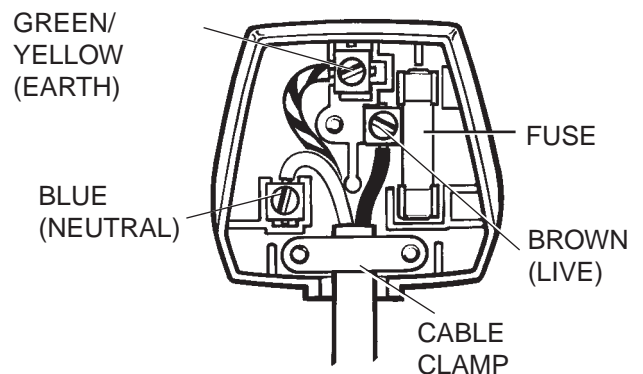

Figure 23 - plug wiring

For best cooking results

For best results and good use of energy:



Hob

- Use good quality cooking pans with thick flat bases. This gives the most efficient energy transfer from the hotplate
- Use pans of the correct diameter. The base should be about the same size as the hotplate
- Use pans which are large enough for the amount of food being cooked to ensure that they do not boil over and cause unnecessary cleaning.
- Use a correctly fitting lid when boiling or stewing to contain heat and improve boiling times.
- Never use recessed or ridged base pans. This wastes energy and gives a longer cooking time
- If the pan base is too small for the hotplate, energy is wasted
- Do not place lids on the hotplates.
- Do not heat an empty pan on the hotplates, as this will damage and discolour the cooking surface at the bottom of the pan.
- Do not use wet pans on the hotplates

Oven

- For even grilling, ensure that the grill pan is positioned centrally below the grill element.
- Ensure that the oven shelf is level. This will ensure even rising of cakes and cooking of food.
- To avoid under/overcooking, reduce or increase cooking times and temperatures to suit personal taste.
- To avoid fat splattering onto the oven interior whilst grilling, ensure that the grill pan is not lined with foil and the grill setting is not too high.
- Do not use pans greater than 52mm (2¼") in height for roasting.

Troubleshooting guide

If you are experiencing problems with your appliances, check the following problems and solutions below before contacting the Helpline.

Hob

Problem	Solution
Nothing works.	Check that: The main hob wall switch is switched to ON. Other appliances are working, to determine if there is general power failure. The circuit breaker in the distribution box has not tripped.
Hotplates are slow to boil or will not simmer.	Check that your pans conform to the recommendations in these instructions.
Marks appearing on hotplates.	The hob surround can be cleaned with warm soapy water and a cream cleaner suitable for hotplates. The sealed hotplates should be cleaned regularly (please refer to the care and cleaning section for more information).

Oven

Problem	Solution
Nothing works	Check that: The main oven wall switch is switched to ON. Other appliances are working to determine if there is a general power failure. The circuit breaker in the distribution box has not tripped.
Grill does not work.	Check that the top heating element <input type="checkbox"/> has been selected on the Function Selector control.
Grill keeps turning ON and OFF.	When the grill is operated at a setting less than 'High' it is controlled by the regulator – this is normal.

Customer Helpline

For help and assistance regarding your oven telephone 0844 871 0011.

Specification

Hob

230 volts ~ 50Hz 5000W

Oven

230 volts ~ 50Hz 2000W

Safe product disposal

To help the environment, Local authority instructions should be followed for the disposal of your product

This appliance/fitting is marked according to the European directive 2002/96/EC on Waste Electrical and Electronic Equipment (WEEE). By ensuring this product is disposed of correctly, you will help prevent potential negative consequences for the environment and human health, which could otherwise be caused by inappropriate waste handling of this product.



■ The symbol on the product, or on the documents accompanying the product, the Crossed Out Wheelie Bin symbol, indicates that this appliance/fitting may not be treated as household waste. Instead it shall be handed over to the applicable collection point for the recycling of electrical and electronic equipment. Disposal must be carried out in accordance with local environmental regulations for waste disposal. For more detailed information about treatment, recovery and recycling of this product, please contact your local authority, your household waste disposal service or the retailer where you purchased the product.

Customer Service, Unit B1, Senator Point, South Boundary Road,
Knowsley, LIVERPOOL L33 7RS
HELPLINE TEL: 0844 871 0011
Monday to Friday (8.30am to 5pm)

We continuously try to improve our products for the benefit of our customers.
For this reason we reserve the right to make changes to any product at any time, without notice.
Instructions ref 26805/140108© 2008